



Suburban Bus Division of the
Regional Transportation Authority

550 West Algonquin Road • Arlington Heights, Illinois 60005

PURCHASE ORDER NO. 230406 B	BEGIN DATE 20-MAY-20
CAPITAL Yes	END DATE 29-MAY-21
F.O.B Destination	BUYER A Bodor
PAYMENT TERMS Net 30 Days	PO: 1 OF 8

C

BLANKET #

230406 B 0

1000484

Jim Sylvester
Stertil-Koni
200 Log Canoe Cir
Stevensville, MD 21666

NOTICE TO VENDOR

For prompt payment, send your invoice with PACE
PO Number, in duplicate to:

ACCOUNTING SECTION
PACE – HEADQUARTERS
550 W ALGONQUIN RD
ARLINGTON HTS, IL 60005-4412
(847) 364-8130

ITM NO	QUANTITY	U/M	SKU NO	DESCRIPTION	VEN PART NO	UNIT PRICE	EXTENSION
1		Each		This confirms contract # 230406 dated May 20, 2020 between Pace, the Suburban Bus Division of the Regional Transportation Authority and Stertil-Koni USA, Inc. for the provision of wireless column lifts, support stands and dollies.		0.00000	
2	3	Each		Wireless Vehicle Lifts (set of 4) #ST-1085-27WA for Pace Southwest		29,941.00000	89,823.00
3	3	Each		Support Stands (set of 4) # SKCVP 5480-18 for Pace Southwest		2,516.00000	7,548.00
4	2	Each		High Lift Wheel Dolly #SKWD 500 for Pace Southwest		3,789.16000	7,578.32



Suburban Bus Division of the
Regional Transportation Authority

550 West Algonquin Road • Arlington Heights, Illinois 60005

PURCHASE ORDER NO. 230406 B	BEGIN DATE 20-MAY-20
CAPITAL Yes	END DATE 29-MAY-21
F.O.B Destination	BUYER A Bodor
PAYMENT TERMS Net 30 Days	PO: 2 OF 8

C

BLANKET

230406 B 0

1000484

Jim Sylvester
Steril-Koni
200 Log Canoe Cir
Stevensville, MD 21666

NOTICE TO VENDOR

For prompt payment, send your invoice with PACE
PO Number, in duplicate to:

ACCOUNTING SECTION
PACE – HEADQUARTERS
550 W ALGONQUIN RD
ARLINGTON HTS, IL 60005-4412
(847) 364-8130

ITM NO	QUANTITY	U/M	SKU NO	DESCRIPTION	VEN PART NO	UNIT PRICE	EXTENSION
5	3	Each		Wireless Vehicle Lifts (set of 4) #ST-1085-27WA for Pace Northwest		29,941.00000	89,823.00
6	3	Each		Support Stands (set of 4) # SKCVP 5480-18 for Pace Northwest		2,516.00000	7,548.00
7	2	Each		High Lift Wheel Dolly #SKWD 500 for Pace Northwest		3,789.16000	7,578.32
8	7	Each		Wireless Vehicle Lifts (set of 4) #ST-1085-27WA for Pace South		29,941.00000	209,587.00



Suburban Bus Division of the
Regional Transportation Authority

550 West Algonquin Road • Arlington Heights, Illinois 60005

PURCHASE ORDER NO. 230406 B	BEGIN DATE 20-MAY-20
CAPITAL Yes	END DATE 29-MAY-21
F.O.B Destination	BUYER A Bodor
PAYMENT TERMS Net 30 Days	PO: 3 OF 8

C

BLANKET #

230406 B 0

1000484

Jim Sylvester
Steril-Koni
200 Log Canoe Cir
Stevensville, MD 21666

NOTICE TO VENDOR

For prompt payment, send your invoice with PACE
PO Number, in duplicate to:

ACCOUNTING SECTION
PACE – HEADQUARTERS
550 W ALGONQUIN RD
ARLINGTON HTS, IL 60005-4412
(847) 364-8130

ITM NO	QUANTITY	U/M	SKU NO	DESCRIPTION	VEN PART NO	UNIT PRICE	EXTENSION
9	7	Each		Support Stands (set of 4) # SKCVP 5480-18 for Pace South		2,516.00000	17,612.00
10	2	Each		High Lift Wheel Dolly #SKWD 500 for Pace South		3,789.16000	7,578.32
11	1	Each		Wireless Vehicle Lifts (set of 4) #ST-1085-27WA for Pace South Holland		29,941.00000	29,941.00
12	1	Each		Support Stands (set of 4) # SKCVP 5480-18 for Pace South Holland		2,516.00000	2,516.00



Suburban Bus Division of the
Regional Transportation Authority

550 West Algonquin Road • Arlington Heights, Illinois 60005

PURCHASE ORDER NO. 230406 B	BEGIN DATE 20-MAY-20
CAPITAL Yes	END DATE 29-MAY-21
F.O.B Destination	BUYER A Bodor
PAYMENT TERMS Net 30 Days	PO: 4 OF 8

C

BLANKET #

230406 B 0

1000484

Jim Sylvester
Steril-Koni
200 Log Canoe Cir
Stevensville, MD 21666

NOTICE TO VENDOR

For prompt payment, send your invoice with PACE
PO Number, in duplicate to:

ACCOUNTING SECTION
PACE – HEADQUARTERS
550 W ALGONQUIN RD
ARLINGTON HTS, IL 60005-4412
(847) 364-8130

ITM NO	QUANTITY	U/M	SKU NO	DESCRIPTION	VEN PART NO	UNIT PRICE	EXTENSION
13	1	Each		Wireless Vehicle Lifts (set of 4) #ST-1085-27WA for Pace North		29,941.00000	29,941.00
14	1	Each		Support Stands (set of 4) # SKCVP 5480-18 for Pace North		2,516.00000	2,516.00
15	1	Each		High Lift Wheel Dolly #SKWD 500 for Pace North		3,789.16000	3,789.16
16	1	Each		Wireless Vehicle Lifts (set of 4) #ST-1085-27WA for Pace North Shore		29,941.00000	29,941.00



Suburban Bus Division of the
Regional Transportation Authority

550 West Algonquin Road • Arlington Heights, Illinois 60005

PURCHASE ORDER NO. 230406 B	BEGIN DATE 20-MAY-20
CAPITAL Yes	END DATE 29-MAY-21
F.O.B Destination	BUYER A Bodor
PAYMENT TERMS Net 30 Days	PO: 5 OF 8

C

BLANKET

230406 B 0

1000484

Jim Sylvester
Steril-Koni
200 Log Canoe Cir
Stevensville, MD 21666

NOTICE TO VENDOR

For prompt payment, send your invoice with PACE
PO Number, in duplicate to:

ACCOUNTING SECTION
PACE – HEADQUARTERS
550 W ALGONQUIN RD
ARLINGTON HTS, IL 60005-4412
(847) 364-8130

ITM NO	QUANTITY	U/M	SKU NO	DESCRIPTION	VEN PART NO	UNIT PRICE	EXTENSION
17	1	Each		Support Stands (set of 4) # SKCVP 5480-18 for Pace North Shore		2,516.00000	2,516.00
18	1	Each		High Lift Wheel Dolly #SKWD 500 for Pace North Shore		3,789.16000	3,789.16
19	2	Each		Wireless Vehicle Lifts (set of 4) #ST-1085-27WA for Pace River		29,941.00000	59,882.00
20	2	Each		Support Stands (set of 4) # SKCVP 5480-18 for Pace River		2,516.00000	5,032.00



Suburban Bus Division of the
Regional Transportation Authority

550 West Algonquin Road • Arlington Heights, Illinois 60005

PURCHASE ORDER NO. 230406 B	BEGIN DATE 20-MAY-20
CAPITAL Yes	END DATE 29-MAY-21
F.O.B Destination	BUYER A Bodor
PAYMENT TERMS Net 30 Days	PO: 6 OF 8

C

BLANKET #

230406 B 0

1000484

Jim Sylvester
Steril-Koni
200 Log Canoe Cir
Stevensville, MD 21666

NOTICE TO VENDOR

For prompt payment, send your invoice with PACE
PO Number, in duplicate to:

ACCOUNTING SECTION
PACE – HEADQUARTERS
550 W ALGONQUIN RD
ARLINGTON HTS, IL 60005-4412
(847) 364-8130

ITM NO	QUANTITY	U/M	SKU NO	DESCRIPTION	VEN PART NO	UNIT PRICE	EXTENSION
21	2	Each		High Lift Wheel Dolly #SKWD 500 for Pace River		3,789.16000	7,578.32
22	6	Each		Wireless Vehicle Lifts (set of 4) #ST-1085-27WA for Pace West		29,941.00000	179,646.00
23	6	Each		Support Stands (set of 4) # SKCVP 5480-18 for Pace West		2,516.00000	15,096.00
24	2	Each		High Lift Wheel Dolly #SKWD 500 for Pace West		3,789.16000	7,578.32

For Internal Use Only

- 1 Project 218075213, Task 11.42.06-001, Exp Type Capital
- 2 Project 218115311, Task 11.42.06-006, Exp Type Capital



Suburban Bus Division of the
Regional Transportation Authority

550 West Algonquin Road • Arlington Heights, Illinois 60005

PURCHASE ORDER NO. 230406 B	BEGIN DATE 20-MAY-20
CAPITAL Yes	END DATE 29-MAY-21
F.O.B Destination	BUYER A Bodor
PAYMENT TERMS Net 30 Days	PO: 7 OF 8

C

BLANKET #

230406 B 0

1000484

Jim Sylvester
Stertil-Koni
200 Log Canoe Cir
Stevensville, MD 21666

NOTICE TO VENDOR

For prompt payment, send your invoice with PACE
PO Number, in duplicate to:

ACCOUNTING SECTION
PACE – HEADQUARTERS
550 W ALGONQUIN RD
ARLINGTON HTS, IL 60005-4412
(847) 364-8130

ITM NO	QUANTITY	U/M	SKU NO	DESCRIPTION	VEN PART NO	UNIT PRICE	EXTENSION
3				Project 218115311, Task 11.42.06-006, Exp Type Capital			
4				Project 218115311, Task 11.42.06-006, Exp Type Capital			
5				Project 218115311, Task 11.42.06-006, Exp Type Capital			
6				Project 218115311, Task 11.42.06-006, Exp Type Capital			
7				Project 218115311, Task 11.42.06-006, Exp Type Capital			
8				Project 218115311, Task 11.42.06-006, Exp Type Capital			
9				Project 218115311, Task 11.42.06-006, Exp Type Capital			
10				Project 218115311, Task 11.42.06-006, Exp Type Capital			
11				Project 218075213, Task 11.42.06-001, Exp Type Capital			
12				Project 218075213, Task 11.42.06-001, Exp Type Capital			
13				Project 218115311, Task 11.42.06-006, Exp Type Capital			
14				Project 218115311, Task 11.42.06-006, Exp Type Capital			
15				Project 218115311, Task 11.42.06-006, Exp Type Capital			
16				Project 218115311, Task 11.42.06-006, Exp Type Capital			
17				Project 218115311, Task 11.42.06-006, Exp Type Capital			
18				Project 218115311, Task 11.42.06-006, Exp Type Capital			
19				Project 218075213, Task 11.42.06-001, Exp Type Capital			
20				Project 218075213, Task 11.42.06-001, Exp Type Capital			
21				Project 218075213, Task 11.42.06-001, Exp Type Capital			
22				Project 218115311, Task 11.42.06-006, Exp Type Capital			
23				Project 218115311, Task 11.42.06-006, Exp Type Capital			
24				Project 218115311, Task 11.42.06-006, Exp Type Capital			
REQUISITION NO. 419437						TOTAL NOT TO EXCEED 824,437.92	



Suburban Bus Division of the
Regional Transportation Authority

550 West Algonquin Road • Arlington Heights, Illinois 60005

C

PURCHASE ORDER NO. 230406 B	BEGIN DATE 20-MAY-20
CAPITAL Yes	END DATE 29-MAY-21
F.O.B Destination	BUYER A Bodor
PAYMENT TERMS Net 30 Days	PO: 8 OF 8

BLANKET #

230406 B 0

1000484

Jim Sylvester
Steril-Koni
200 Log Canoe Cir
Stevensville, MD 21666

NOTICE TO VENDOR

For prompt payment, send your invoice with PACE
PO Number, in duplicate to:

ACCOUNTING SECTION
PACE – HEADQUARTERS
550 W ALGONQUIN RD
ARLINGTON HTS, IL 60005-4412
(847) 364-8130

ITM NO	QUANTITY	U/M	SKU NO	DESCRIPTION	VEN PART NO	UNIT PRICE	EXTENSION
PLUS OTHERS							
							5/21/20
					Signature		Date

Contract No. (230406)

**INVITATION FOR BID NO. 419131
WIRELESS MOBILE COLUMN LIFTS AND SUPPORT STANDS
SPECIAL CONTRACT CONDITIONS/BID PRICE**

THIS CONTRACT is entered into (May 20, 2020) by and between Pace, Suburban Bus Division of the Regional Transportation Authority (hereinafter called Pace) and the Bidder/Contractor indicated below.

1. **General Description:** Pace is seeking firm fixed unit pricing for the purchase of wireless mobile column lifts, support stands and high lift wheel dollies for various Pace locations.
2. **Basis of Award:** This contract will be awarded to the lowest responsive and responsible bidder on the basis of the Grand Total. This Contract shall be effective as of the date when it is signed by Pace. The prices submitted with the Bid will be firm, fixed unit prices for the duration of the contract. Bids shall be irrevocable for a period of ninety (90) days.
3. **Approved Products:** The bidding Contractor must be authorized by the OEM. All equipment must be new unless otherwise specified. Products proposed shall comply with the original equipment manufacturer's requirements or specifications and will not compromise any OEM warranties. In cases where an item is identified in these Contract documents by a manufacturer's name, trade name, catalog number or reference, it is understood that the Contractor shall furnish the item so identified or shall furnish an "equal" unless specified elsewhere in the bid documents. The specific article, equipment or material mentioned shall be understood as establishing the type, function, and minimum standard of design, efficiency, quality, and performance desired and shall not be construed in such a manner as to exclude manufacturer's products of comparable design, efficiency, quality, and performance. Bid quotations on other makes or catalog numbers will be considered for current or future purchases provided the Contractor clearly states that an "equal" is proposed and they furnish sufficient information with their bid to determine compliance.
4. **Request for Pre-Approved Equal:** Pace will consider products equal in function and performance to those detailed within Exhibit C, Specifications. Bidders proposing products shall submit sufficient supporting documentation, drawings, and literature for Pace to review the products and determine equivalence as detailed within Exhibit C, Specifications by **2:00 PM on Monday November 18, 2019**. Acceptance of products is at the sole discretion of Pace.
5. **Delivery:** Delivery shall be complete within 120 calendar days upon receipt of an executed purchase order. Delivery, training and all other charges must be included in the Bid Price. No additional charges will be allowed. The specified items and quantities shall be delivered to the locations listed within Exhibit D – Delivery Locations.
6. **Pace DBE Requirements:** Pace has determined that ZERO PERCENT (0%) DBE participation is required for this Contract. Pace encourages the Prime Contractor to offer contracting opportunities to the fullest extent possible through outreach and recruitment activities.
7. **Insurance Requirements:** The successful bidder will be required to provide evidence of all required insurance coverage, limits, endorsements, etc. for the duration of the contract plus one additional year. Evidence of required insurance coverage shall be provided on an Acord 25-S (or equivalent) Certificate of Insurance form. The Certificate of Insurance and required policy endorsements (CG 20 10 or CG 20 37 or CG 20 26, CA 2048, etc.) must be submitted to and approved by Pace *prior to* contract award and *prior to* the required insurance policy expiration date. For a complete list of all insurance coverage requirements, please see Exhibit E, of this IFB.
8. **Indemnification:** The Contractor shall indemnify, keep and save harmless Pace, its agents, officials and

employees against all injuries, losses, claims, suits, costs and expenses which may accrue against Pace arising out of the services or products provided under this Contract, including any copyright or patent infringement or claim of such infringement arising from the intended use of goods or services furnished hereunder. The Contractor agrees to indemnify and hold harmless Pace, its employees and Officers, from any and all claims by persons or entities that may arise out of and in the course of its performance of this contract, and from any and all claims by its subcontractors, employees or independent contractors which may arise out of and in the course of performance of this Contract. Any and all claims for unemployment benefits and worker's compensation benefits are expressly waived by the Contractor, its subcontractors, employees, and independent contractors, who agree to maintain separate policies of insurance as hereinafter are provided in this agreement. The Contractor shall retain independent counsel and at its expense shall assume and defend all claims, demands and suits covered in this indemnification section.

9. **Payment/Invoicing:** All invoices are to reference the contract number, description of services, location services were rendered, part number, quantity shipped, unit prices, and extensions. The Contractor shall provide a detailed listing, in an invoice or series of invoices, of all equipment furnished to Pace as part of this Contract. All equipment should be itemized with corresponding model and serial numbers where applicable. The itemized listing should be provided on an invoice with the shipment date and delivery location indicated. If the Contractor's invoices are billed as progressive or acceptance payments, any equipment shipped to Pace during that billing period must be itemized on an invoice with the associated cost for each item. If equipment is provided and shipped to Pace by a subcontractor, the Contractor is responsible for obtaining and submitting the itemized listing of equipment that is shipped to Pace. The Contractor will invoice Pace at 550 W. Algonquin Road, Arlington Heights, IL 60005. Electronic invoices shall be submitted to accounts.payable@pacebus.com. Payment will be made within 30 days of receipt of an approved invoice.
10. **Retention of Records:** The Contractor shall maintain records to verify the actual time devoted and costs incurred. These records shall be maintained for a minimum period of five years after completion of the contract at which time the Contractor may request permission from Pace to dispose of the records. Upon fifteen (15) days notice from Pace, all time sheets, billings, and other documentation used in preparing said records shall be made available for inspection, copying, or auditing by Pace at any time during normal business hours at Pace's headquarters location.
11. **Ownership of Records:** Pace shall retain ownership of all plans, specifications, and related documents, and all other documents, including but not limited to those mentioned above, prepared by the Contractor under the Contract.
12. **Audit and Inspection of Records:** The Contractor shall permit the authorized representative of Pace, the Regional Transportation Authority, the State of Illinois, the U.S. Department of Transportation and the Comptroller General of the United States to inspect and audit all data and records of the Contractor relating to his performance under the Contract. Contractor acknowledges and agrees that representatives of the Office of Executive Inspector General and Office of Inspector General of Pace, have the authority and ability to: examine any record, information, data, reports, plans, projections, matters, contracts, correspondence, or other materials, and interview any employee, officer, or agent of Contractor with respect to performance of the terms, and provision of goods and/or services of this contract. Contractor agrees to cooperate fully and expeditiously with any investigation or audit conducted by an Inspector General.
13. **Termination for Insufficient Funds:** It is expressly agreed that Pace's obligation to pay for the services provided under this Contract shall be limited to the availability of funds from (1) Pace's revenues and budget for the fiscal years covered by this Contract and from (2) funds that may be received from the Federal Transit Administration, the Illinois Department of Transportation, the Regional Transportation Authority, and/or other funding agencies to be specifically applied for the services provided under this

Contract. In the event that Pace determines that funds are not available from these sources to pay any remaining unpaid part or parts of the Contract, Pace's obligations to pay such unpaid part or parts of the Contract shall be terminated immediately and Pace shall have no further obligations under the Contract in respect to payment, with the exception of payment for authorized services already performed and costs already accrued.

14. **Exhibits:** The following Exhibits are attached hereto and become a part of any award that may result. If there is any conflict in the provisions contained in these Exhibits, then the more stringent shall take precedence.

Exhibit A – Special Contract Conditions/Bid Price

Exhibit B – General Contract Conditions

Exhibit C – Specifications

Exhibit D – Delivery Locations

Exhibit E – Insurance Requirements

15. **Bid Submittal Check List:** The following documents should be submitted with your bid or it may be considered non-responsive.

Bidders are further cautioned not to qualify their bids by modifying the contract documents, either by alteration or supplemental statements or documents (including but not limited to quotation forms, agreement documents, or exceptions). All bids are to be in accordance with this Invitation for Bid and become the property of Pace. Bids that are not so made may be rejected as non-responsive.

- Complete the Bidders Bid Sheet
- Sign the Non-Collusion Affirmation at the bottom of the Bidders Bid Sheet
- Complete and sign the Contract Signature Page
- Acknowledge any addenda on page 7 of Exhibit A; submit all documents as instructed by any addenda
- For any product proposed, submit technical specifications/documentation/literature proving equivalence to Exhibit C, Specifications.
- Sign, date and complete the Buy America Certification
- Complete and sign the Certification of Restrictions on Lobbying
- Sign the Contractor's Certification Regarding Suspension and Debarment
- Submit one (1) set of **all** bid documents in a sealed envelope stating IFB No. 419131 for Wireless Mobile Column Lifts and Support Stands.

Any questions regarding this Invitation for Bid must be submitted no later than 2:00 PM on Monday November 18, 2019. Bidders are encouraged to submit requests for pre-approved equals during the question period. All requests for pre-approved equals shall be submitted with sufficient supporting documentation for Pace to review and to determine compliance. Questions regarding this IFB shall be submitted in writing to Amanda Bodor, Contract Buyer II, Amanda.bodor@pacebus.com or via fax at 847-228-4204. Questions submitted after this date and time will not be accepted.

The bid opening date is **Thursday December 12, 2019 at 2:00 P.M.** at Pace Headquarters, 550 West Algonquin Road, Arlington Heights, Illinois 60005. Any bids received after this date and time or via email will be rejected.

**INVITATION FOR BID NO. 419131
WIRELESS MOBILE COLUMN LIFTS AND SUPPORT STANDS
BIDDERS BID
(SUBMIT ONE (1) BID)**

- The unit pricing quoted must be firm and include delivery, training, and all other applicable charges. No additional charges will be allowed. In the event of a discrepancy between the unit cost and total, the unit cost shall prevail.
- Bidders shall indicate the manufacturer and model number to be supplied in the space provided.
- Bidders shall provide sufficient information with the bid to determine compliance. Compliance shall be determined at Pace's sole discretion. Pace must have **all technical information or product literature/brochure with the bid in order to prove equivalence for the proposed products. Lack of sufficient documentation will render the bid as non-responsive.**
- Bidders are **not** to modify this bid by alternation and/or supplemental statements or documents which may be cause for your bid to be rejected as non-responsive.

Description	Qty.	Unit Cost	Total
Vehicle Lifts (set of 4). 72,000 lb. capacity as detailed within Exhibit C, Specifications for Pace Southwest Manufacturer part & model # <u>ST-1085-27WA</u>	3	\$ <u>29,941</u>	\$ <u>89,823</u>
Support Stands (set of 4) as detailed within Exhibit C, Specifications for Pace Southwest Manufacturer part & model # <u>SKCVP 5480-18</u>	3	\$ <u>2,516</u>	\$ <u>7,548</u>
High Lift Wheel Dolly as detailed within Exhibit C, Specifications for Pace Southwest Manufacturer part & model # <u>SKWD 500</u>	2	\$ <u>3,789.16</u>	\$ <u>7,578.32</u>
Vehicle Lifts (set of 4). 72,000 lb. capacity as detailed within Exhibit C, Specifications for Pace Northwest Manufacturer part & model # <u>ST-1085-27WA</u>	3	\$ <u>29,941</u>	\$ <u>89,823</u>
Support Stands (set of 4) as detailed within Exhibit C, Specifications for Pace Northwest Manufacturer part & model # <u>SKCVP 5480-18</u>	3	\$ <u>2,516</u>	\$ <u>7,548</u>
High Lift Wheel Dolly as detailed within Exhibit C, Specifications for Pace Northwest Manufacturer part & model # <u>SKWD 500</u>	2	\$ <u>3,789.16</u>	\$ <u>7,578.32</u>
Vehicle Lifts (set of 4). 72,000 lb. capacity as detailed within Exhibit C, Specifications for Pace South Manufacturer part & model # <u>ST-1085-27WA</u>	7	\$ <u>29,941</u>	\$ <u>209,587</u>

Support Stands (set of 4) as detailed within Exhibit C, Specifications for Pace South Manufacturer part & model # <u>SKCVP 5480-18</u>	7	\$ <u>2,514</u>	\$ <u>17,612</u>
High Lift Wheel Dolly as detailed within Exhibit C, Specifications for Pace South Manufacturer part & model # <u>SKWD500</u>	2	\$ <u>3789.14</u>	\$ <u>7578.32</u>
Vehicle Lifts (set of 4). 72,000 lb. capacity for Pace South Holland Manufacturer part & model # <u>ST-1085-270A</u>	1	\$ <u>29,941</u>	\$ <u>29,941</u>
Support Stands (set of 4) as detailed within Exhibit C, Specifications for Pace South Holland Manufacturer part & model # <u>SKCVP 5480-18</u>	1	\$ <u>2514</u>	\$ <u>2514</u>
Vehicle Lifts (set of 4). 72,000 lb. capacity as detailed within Exhibit C, Specifications for Pace North Manufacturer part & model # <u>ST-1085-270A</u>	1	\$ <u>29,941</u>	\$ <u>29,941</u>
Support Stands (set of 4) as detailed within Exhibit C, Specifications for Pace North Manufacturer part & model # <u>SKCVP 5480-18</u>	1	\$ <u>2514</u>	\$ <u>2514</u>
High Lift Wheel Dolly as detailed within Exhibit C, Specifications for Pace North Manufacturer part & model # <u>SKWD500</u>	1	\$ <u>3789.14</u>	\$ <u>3789.14</u>
Vehicle Lifts (set of 4). 72,000 lb. capacity as detailed within Exhibit C, Specifications for Pace North Shore Manufacturer part & model # <u>ST1085-270A</u>	1	\$ <u>29,941</u>	\$ <u>29,941</u>
Support Stands (set of 4) as detailed within Exhibit C, Specifications for Pace North Shore Manufacturer part & model # <u>SKCVP 5480-18</u>	1	\$ <u>2514</u>	\$ <u>2514</u>
High Lift Wheel Dolly as detailed within Exhibit C, Specifications for Pace North Shore Manufacturer part & model # <u>SKWD 500</u>	1	\$ <u>3789.14</u>	\$ <u>3789.14</u>
Vehicle Lifts (set of 4). 72,000 lb. capacity as detailed within Exhibit C, Specifications for Pace River Manufacturer part & model # <u>ST-1085-270A</u>	2	\$ <u>29,941</u>	\$ <u>59882</u>

Support Stands (set of 4) as detailed within Exhibit C, Specifications for Pace River Manufacturer part & model # <u>SKCVP-5480-1R</u>	2	\$ <u>2516</u>	\$ <u>5,032</u>
High Lift Wheel Dolly as detailed within Exhibit C, Specifications for Pace River Manufacturer part & model # <u>SKWD 500</u>	2	\$ <u>3789.16</u>	\$ <u>7578.32</u>
Vehicle Lifts (set of 4). 72,000 lb. capacity as detailed within Exhibit C, Specifications for Pace West Manufacturer part & model # <u>ST-1085-270A</u>	6	\$ <u>29941</u>	\$ <u>179,646</u>
Support Stands (set of 4) as detailed within Exhibit C, Specifications for Pace West Manufacturer part & model # <u>SKCVP 5480.1R</u>	6	\$ <u>2516</u>	\$ <u>15,096</u>
High Lift Wheel Dolly as detailed within Exhibit C, Specifications for Pace West Manufacturer part & model # <u>SKWD 500</u>	2	\$ <u>3789.16</u>	\$ <u>7578.32</u>

GRAND TOTAL (Not To Exceed Contract)	\$ <u>828,227.08</u>
---	----------------------

NON-COLLUSION AFFIRMATION

IMPORTANT: This affirmation must be signed and submitted with the bid/proposal.

The bidder or proposer submitting this bid or proposal hereby affirms that such bid/proposal was not made in the interest of or on behalf of any undisclosed person, partnership, company, organization or corporation; that such bid/proposal is genuine and not collusive or sham, and that said bidder/proposer has not been a party to any agreement or collusion among bidders/proposers or prospective bidders/proposers in restraint of freedom of competition by agreement to bid a fixed price, or otherwise, or to refrain from bidding/proposing and has not, directly or indirectly, by agreement, communication or conference with anyone attempted to induce action prejudicial to the interest of the Suburban Bus Division of the Regional Transportation Authority (Pace) or any bidder/proposer or anyone else interested in the proposed Contract. The bidder/proposer further certifies that it is not barred from contracting with any State or unit of local government as a result of a violation of either Section 33E-3 or Section 33E-4 of Article 33E of the Illinois Criminal Code (III. Rev. Stat. Chap.38,33E-1,ET.SEQ).

 (Signature of Person Affirming Bid/Proposal)

INVITATION FOR BID NO. 419131
WIRELESS MOBILE COLUMN LIFTS AND SUPPORT STANDS
CONTRACT SIGNATURE PAGE

Addendum Acknowledgment: The bidder hereby acknowledges receipt of the following Addenda that are incorporated herein by reference. (If there were No Addenda, write "NONE") _____. **Failure to acknowledge Addenda may be cause for the bid to be considered non-responsive.**

Addendum No. ____

Addendum No. ____

Addendum No. ____

IN WITNESS WHEREOF, the parties hereto have executed this Contract on the dates recited below:

CONTRACTOR

**PACE, SUBURBAN BUS DIVISION OF THE
REGIONAL TRANSPORTATION AUTHORITY**

Stertil-Koni USA, Inc.
Company Name

200 Log Canoe Circle
Street Address

Stevensville MD 21166
City, State & Zip Code

Authorized Signature

12/09/2019
Date

Sean Dell Amore
Printed/Typed Name

President
Title

410. 643. 9001 / 410 643. 8901
Telephone Number and Fax Number

lifts@stertil-koni.com
E-mail Address

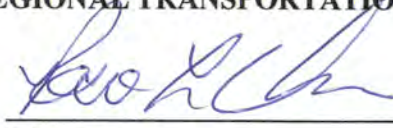
Signature

Rocco L. DONATELLI
Printed/Typed Name

EXECUTIVE DIRECTOR
Title

5/21/20
Date



Rocky Donahue
Executive Director

February 19, 2020

Mr. Jean DellAmore
Steril-Koni USA, Inc.
200 Log Canoe Circle
Stevensville, MD 21666
jean@steril-koni.com

**Reference: Invitation for Bid (IFB) 419131
Wireless Mobile Column Lifts and Support Stands**

Subject: Request for Bid Verification

Dear Mr. DellAmore,

During our bid analysis for IFB No. 419131, Wireless Mobile Column Lifts and Support Stands, Pace opened and recorded all bids. Pace discovered mathematical errors in the calculation of the Grand Total in *Exhibit A, Bidders Bid*. The following item had a calculation error:

- Grand Total
 - The Grand Total written is **\$828,227.08**
 - The Grand Total calculated by Pace for this is **\$824,437.92**.

Before Pace can proceed with the final analysis, we must request verify and obtain the following:

A signature by the person who signed the bid, or authorized representative of your company, indicating the following:

- a) Steril-Koni USA Inc. verifies that the Grand Total of \$824,437.92 calculated by Pace is correct and is the bid price originally intended and conforms to the requirements of IFB 419131.

or

- b) Steril-Koni USA Inc. wishes to withdraw your bid without prejudice.

Pace also noted upon the Contract Signature Page that Steril-Koni USA, Inc provided signature on Pace's signature line. Pace requests Steril-Koni USA, Inc. provide an original signature on the Contractor signature line, using the original signatory information and date of 12/9/2019.

Please return the bid verification to my attention no later than 2:00 P.M. on Friday, February 21, 2020. If you have any questions, please contact Amanda Bodor at (847) 228-2370 or Amanda.bodor@pacebus.com.

Sincerely,

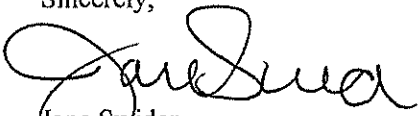

Jane Swider
Department Manager, Purchasing

ACKNOWLEDGMENT OF BID VERIFICATION

Stertil-Koni USA Inc. hereby verifies that the intended bid of \$824,437.92 is accurate, correct, and conforms to all the requirements of IFB 419131.

Stertil-Koni USA Inc. wishes to withdraw the bid without prejudice.



Authorized Signature of Original Bid Signatory



Date



Print Name



Title

PACE SUBURBAN BUS SERVICE
INSTRUCTIONS TO CONTRACTORS & GENERAL CONTRACT CONDITIONS
MATERIALS AND SUPPLIES WITH SERVICES CONTRACTS

SECTION A - INSTRUCTIONS TO CONTRACTORS 1

1. Documents 1
2. Authorities and Limitations 1
3. Conditions of Acceptance 1
4. Withdrawal of Bids 2
5. Errors in Bids 2
6. Irregular Bids 2
7. Additional Charges 2
8. Contractors Record and Qualifications 2
9. Modifications to Contract 2
10. Cash Discounts 2
11. Performance 2

SECTION B - GENERAL TERMS AND CONDITIONS 2

1. Delivery 2
2. Entire Agreement 3
3. Indemnification 3
4. Assignments 3
5. Waiver 3
6. Termination 3
7. Price Warranty 3
8. Payment 3
9. Processing Data Between Years and Centuries 3
10. Regulatory Compliance 3
11. Equal Employment Opportunity 4
12. Disadvantaged Business Enterprise 4
 - DBE Responsiveness Requirements 4
 - DBE Responsibility Requirements 4
 - Calculating DBE Participation 5
 - Good Faith Efforts 8
 - Reconsideration 9
 - Document Requirements 10
 - Schedule A Checklist 13
 - Schedule A – Summary of DBE Participation 14
 - Schedule B Checklist 15
 - Schedule B – Confirmation of Proposed DBE Participation 16
 - Schedule C – Affidavit of DBE/Non-DBE Joint Venture 17
13. Disclosures 23
14. Conflict of Interest 23
15. Conflict In Provisions 23
16. Trade Names 23
17. Warranties 23
18. Approximate Quantities and Line Items 23
19. Retention of Records 23
20. Bid Protest Procedures 23
21. Illinois Freedom of Information Act 26
22. Disputes Resolution 27

SECTION C - FTA/IDOT/RTA REQUIREMENTS 28

1. Fly America Requirements 28
2. Surface Transportation Assistance Act/Buy America 28
3. Charter Service Operations 28

- 4. School Bus Operations 29
- 5. Cargo Preference - Use of United States Flag Vessels 29
- 6. Seismic Safety..... 29
- 7. Energy Conservation Requirements 29
- 8. Clean Water Requirements 29
- 9. Byrd Anti Lobbying Amendment 29
- 10. Audit 30
- 11. Federal Changes 30
- 12. Clean Air Requirements..... 30
- 13. Recovered Materials 30
- 14. Davis-Bacon and Copeland Anti-Kickback Acts 30
- 15. Contract Work Hours and Safety Standards 34
- 16. No Obligation by the Federal Government 34
- 17. Program Fraud and False or Fraudulent Statements or Related Acts 35
- 18. Ineligible Contractors and Subcontractors..... 35
- 19. Contracts Involving Federal Privacy Act Requirements 35
- 20. Civil Rights 35
- 21. Patent Rights 36
- 22. Copyright and Rights in Data 36
- 23. Transit Employee Protective Provisions 36
- 24. Drug and Alcohol Testing..... 37
- 25. Incorporation of Federal Transit Administration (FTA) Terms..... 37
- 26. Veterans Employment..... 37
- 27. Illinois Prevailing Wage Act (820 ILCS 130) 37
- 28. Bid Evaluation Requirements 37
- 29. The Americans with Disabilities Act 38
- 30. Use of Metric Units of Measure and English Language 38
- 31. Interest of Members of Congress 38
- 32. Financial Assistance Contract..... 38
- 33. State of Illinois Ineligible Contractors and Subcontractors..... 38

- BUY AMERICA CERTIFICATION..... 39-40
- CERTIFICATION OF RESTRICTIONS ON LOBBYING 41
- CERTIFICATION REGARDING SUSPENSION AND DEBARMENT 42

PACE, SUBURBAN BUS SERVICE
INSTRUCTIONS TO CONTRACTORS & GENERAL CONTRACT CONDITIONS
MATERIALS AND SUPPLIES WITH SERVICES CONTRACTS

The following instructions, terms and conditions shall apply to Pace solicitations and Contracts for materials and supplies. All Pace Contracts shall be governed by Illinois Law. All Bidders or Proposers shall be referred to as "Contractors" and all bids or offers as "Bids" or "Bid Quotations" in this section of the Contract Specifications.

SECTION A – INSTRUCTIONS TO CONTRACTORS

1. Documents: The Contractor declares he has fully examined this Invitation for Bid or Request for Proposal including all attachments, exhibits and addenda as applicable and that he is familiar with all of the conditions effecting the Contract, and understands that in making this quotation the Contractor waives all right to plead any misunderstanding regarding same. The Contractor's quotation shall comply with all federal, state and local laws, rules and regulations applicable.

Award shall be made by mailing a properly executed Contract to the successful bidder.

2. Authorities and Limitations

- 2.1 This Contract is made and shall be interpreted under the laws of the State of Illinois and the Contractor agrees and consents that only the courts of Illinois and Federal appellate courts shall have jurisdiction over controversies arising out of this Contract.
- 2.2 The articles, sections, paragraphs or other headings shown are for convenience and reference only and in no way define, limit or describe the scope or intent of this Contract or its Exhibits.
- 2.3 This Contract together with any other document expressly incorporated herein contain the entire agreement between the parties hereto and there are no prior or contemporaneous oral or written understandings or agreements binding on Pace affecting the subject matter of this Contract other than those expressly referred to therein. No agreement, other understanding or acknowledgment, invoice, or other form used by the Contractor to modify or alter the provisions of this order resulting from acceptance by the Contractor of this Contract will be binding upon Pace unless made in writing and signed by Pace's authorized representative.
- 2.4 All services/work shall be performed under the direction of the Pace Chief Procurement Officer who alone shall have the authority to bind Pace and to exercise the rights, responsibilities, authorities and functions vested within the Contract documents, except that the Chief Procurement Officer shall have the right to designate authorized representatives to act on their behalf. Wherever any provision in this Contract specifies an individual (such as, but not limited to, Engineer, Resident Engineer, Inspector, Site Manager or Architect) or organization, whether Pace or private, to perform any act on behalf of or in the interests of Pace, that individual or organization shall be deemed to be Pace Chief Procurement Officer authorized representative under this Contract but only to the extent so specified.

Pace's Chief Procurement Officer may, at any time during the performance of this Contract, vest in any such authorized representatives, additional power and authority to act on their behalf or designate additional representatives, specifying the extent of their authority to act or designate additional representatives to the extent deemed necessary.

- 2.5 The Contractor shall perform the Contract in accordance with any order (including but not limited to instruction, direction, interpretation or determination) issued by an authorized representative in accordance with the authority to act for the Pace Chief Procurement Officer, but the Contractor assumes all the risk and consequences of performing the Contract in accordance with any order (including but not limited to instruction, direction, interpretation, or determination) of anyone not authorized to issue such order.
3. Conditions of Acceptance: This Invitation for Bid or Request for Proposal expressly limits acceptance to the terms and conditions stated herein and any supplementary or additional terms and conditions annexed hereto or incorporated herein by reference. Any additional or different terms and conditions proposed by the Contractor are objected to and hereby rejected unless accepted by Pace prior to the time and date of bid opening. The Contractor further understands and agrees that if this bid is accepted, the Contractor is to furnish any and all of the items or services upon which prices are quoted, at the price and delivery time stated, subject to all terms, conditions, and requirements set forth in the bid and in the resulting Contract. Pace reserves the right to extend the bid quotation opening date and to reject any or all bid quotations or any part thereof. Pace further reserves the right to excuse informalities in the bid quotations and bidding when, in the judgment of Pace, the best interests of Pace will be served and the spirit of competition will be maintained.

4. Withdrawal of Bids: Once submitted, bids may only be withdrawn with Pace's consent prior to bid opening and may be superseded by a subsequent timely bid. Any bid received after the time and date specified for opening, or any postponement thereof, will not be considered. Bids shall be irrevocable for a period of ninety (90) days after the opening thereof by Pace.
5. Errors in Bids: The Contractor is cautioned to verify any Bids made before submission. No bid may be withdrawn or changed after it has been opened unless Pace has determined:
 - a. That an obvious mistake of a mechanical or clerical nature was actually made; not just an error in judgment, such as underestimating material or service costs.
 - b. That the "mistaken" Contractor was not guilty of culpable negligence in making the error, or in delay in communicating the fact to Pace on discovery.
6. Irregular Bids: The Contractor understands that the bid must show the unit prices for all material or services which are proposed to be furnished, and that extensions must be shown and that if not so shown, their bid may be rejected as irregular.
7. Additional Charges: The price quoted for each item is the full purchase price, including packaging and delivery charges, and includes all premiums on bonds, material or service costs, patent royalties and all other overhead charges of every kind and nature. The Contractor warrants that prices include all charges for packing, crating and transportation to F.O.B. points.
8. Contractors Record and Qualifications: The Contractor, within forty-eight hours after being requested in writing by Pace, shall furnish evidence satisfactory to Pace of the Contractor's ability and responsibility, financial and otherwise, to furnish the material or service specified in the manner and at the time prescribed and in accordance with the specifications of Pace.
9. Modifications to Contract
 - a. For Request for Proposals (RFPs), requests for any change in the Contract proposal documents must be submitted as Contract exceptions along with the technical and price proposals on the RFP due date.
 - b. Request for any change in the Contract after award shall be submitted in writing to Chief Procurement Officer for prior approval. Oral change orders are not permitted. No change in the Contract shall be made except in writing signed by the Chief Procurement Officer or a designated representative. The Contractor shall be liable for all costs resulting from, and/or for satisfactorily correcting, any specification change not properly ordered by written modification to the Contract and signed by Pace.
10. Cash Discounts: The Contractor offering the lowest bid shall be determined by comparing the gross individual unit prices, or the gross bid total, as applicable. Cash (early payment) discounts are not taken into consideration when selecting the lowest bid.
11. Performance: It is understood and agreed that time of performance is of the essence of this Contract. If the Contractor is delayed in the performance of the services purchased under the Contract by a cause beyond his control, he must immediately upon receiving knowledge of such delay, give written notice to Pace and request an extension of time for completion of the Contract. Pace shall examine the request and determine if the Contractor is entitled to an extension. Pace shall notify the Contractor of the decision in writing.

SECTION B – GENERAL TERMS AND CONDITIONS

1. Delivery: It is understood and agreed that time of delivery is of the essence of this Contract. If the Contractor is delayed in the delivery of goods or services purchased under the Contract by a cause beyond his control, he must immediately upon receiving knowledge of such delay, give written notice to Pace and request an extension of time for completion of the Contract. Pace shall examine the request and determine if the Contractor is entitled to an extension. Pace shall notify the Contractor of the decision in writing.
2. Entire Agreement: This Contract contains the entire agreement of the parties. It may not be modified or terminated orally, and no claimed modification, termination, or waiver shall be binding on Pace unless in writing signed by the Chief Procurement Officer or the duly authorized representative. No modification or waiver shall be deemed effected by the Contractor's acknowledgment or confirmation containing other or different terms. All titles to clauses contained in this Contract are for identification only and shall not be construed as being a substantive part of the agreement. The Section headings contained in this Contract are for convenience and reference only and in no way define, limit, or describe the scope or intent of this Contract.

3. **Indemnification:** The Contractor shall indemnify, keep and save harmless Pace, its agents, officials and employees against all injuries, losses, claims, suits, costs and expenses which may accrue against Pace arising out of the services or products provided under this Contract, including any copyright or patent infringement or claim of such infringement arising from the intended use of goods or services furnished hereunder. The Contractor agrees to indemnify and hold harmless Pace, its employees and Officers, from any and all claims by persons or entities that may arise out of and in the course of its performance of this Contract, and from any and all claims by its subcontractors, employees or independent contractors which may arise out of and in the course of performance of this Contract. Any and all claims for unemployment benefits and worker's compensation benefits are expressly waived by the Contractor, its subcontractors, employees, and independent contractors, who agree to maintain separate policies of insurance as hereinafter are provided in this agreement. The Contractor shall retain independent counsel and at its expense shall assume and defend all claims, demands and suits covered in this indemnification section.
4. **Assignments:** The Contractor agrees that neither this Contract nor any part of it or any of the monies due from this Contract may be assigned without the prior written consent of Pace. Any successor or assign under this Contract will be required to accede to all of the terms, conditions and requirements of this Contract as a condition precedent to such succession or assignment. Assignment of any portion of the work by subcontract must be approved in advance by Pace, in writing. Pace reserves the right to assign all or part of the specified deliverables in this Contract as originally advertised, competed, evaluated, and awarded including base and option quantities.
5. **Waiver:** Pace's failure to promptly enforce any of the conditions of this Contract shall not constitute a waiver of any of Pace's other rights.
6. **Termination:** Pace may terminate this Contract at any time hereafter, with or without cause, by giving written notice to the Contractor at the address specified above. Termination shall be effective upon receipt of such notice by the Contractor. If Pace terminates this Contract other than for breach thereof by the Contractor, Pace agrees to pay the Contractor, and the Contractor agrees to accept as its sole remedy, cancellation charges equal to the remaining unpaid costs accrued and obligated to date of cancellation. In the event of breach or violation by the Contractor of any provision of the Contract, Pace may allow the Contractor a reasonable opportunity to cure the breach prior to termination under this provision. Upon termination of this Contract for breach by the Contractor, the Contractor assumes liability for all excess costs incurred by Pace to complete the Scope of Services specified in the Contract.
7. **Price Warranty:** The Contractor warrants that the unit price(s) charged herein do not exceed the unit prices charged by the Contractor to any other customers in substantially similar transactions. The Contractor agrees to make any price rebate which this warranty may require.
8. **Payment:** Payments will be made in accordance with the terms in the Contract, or the Contractor's invoice, whichever are more favorable to Pace. The payment date shall be calculated from the receipt of invoice or final acceptance of the goods or services, whichever is later in accordance with the Local Government Prompt Payment Act. Under the Act, Pace will pay the Contractor within thirty (30) days of its approval of the Contractor's invoice. The Contractor agrees that it shall pay all subcontractors who have completed satisfactory work under the subcontract no later than thirty (30) days from receipt of payment by Pace. The Contractor further agrees to return any retainage payments withheld from subcontractor within thirty (30) days after the subcontractor's work is satisfactorily completed. This requirement is also applicable to all sub-tier subcontractors and suppliers, and shall be made a part of all subcontracts and agreements. Pace is exempt from local, state, and federal taxes.
9. **Processing Data Between Years and Centuries:** Hardware, software and firmware delivered under this Contract shall be able to accurately process data between years and centuries.
10. **Regulatory Compliance:** All goods and services furnished hereunder by the Contractor shall comply with all Federal, State and local laws, rules and regulations as applicable, including, but not limited to:
 - a. Surface Transportation Assistance Act of 1982, Section 165a of Public Law 100-17 (Buy America).
 - b. The Occupational Safety and Health Act of 1970, and the Illinois Toxic Substance Act, with respect to the design, construction or use for their intended purpose of said goods or services and the labeling of all goods and containers for the protection and safety of persons and property.
11. **Equal Employment Opportunity:** In connection with the execution of this Contract, the Contractor shall not discriminate against any employee or applicant for employment because of race, religion, color, sex, age, national origin, ancestry, marital status, physical or mental handicap or unfavorable discharge from military service. The Contractor shall take affirmative actions to ensure that applicants are employed, and that employees are treated during their employment, without regard to their race, religion, color, sex, age, national

origin, ancestry, marital status, physical or mental handicap or unfavorable discharge from military service. Such action shall include but not be limited to, the following: employment, upgrading, demotion, transfer, recruitment, advertising, layoff, termination, rates of pay or other forms of compensation, and selection for training, including apprenticeship. If the Contractor is required to file an Affirmative Action Plan with any federal, state or local agency, the Contractor assures Pace that it is in full compliance with such filing requirements.

The Contractor agrees to comply with all provisions of the "Illinois Human Rights Act", 775 ILCS Title 5, as now or hereafter amended and with all rules, regulations, and guidelines on discrimination in employment as now or hereafter promulgated thereunder. All such provisions, rules, resolutions and guidelines, including but not limited to; Article VI "Equal Opportunity Clause" of the Rules and Regulations of the Department of Human Rights are hereby incorporated into the Contract by reference.

12. Disadvantaged Business Enterprise Compliance Requirements: Pursuant to Federal regulations for Disadvantaged Business Enterprise (DBE) programs, Contractor agrees to the following DBE assurances, and agrees to include this clause in all subcontracts:

The Contractor shall not discriminate on the basis of race, color, national origin, or sex in the performance of this contract. The Contractor shall carry out applicable requirements of 49 CFR Part 26 in the award and administration of DOT-assisted contracts. Failure by the Contractor to carry out these requirements is a material breach of this contract, which may result in the termination of this contract or such other remedy as Pace deems appropriate.

PACE HAS SET A GOAL OF 0 % DBE PARTICIPATION FOR THIS CONTRACT

DBE RESPONSIVENESS REQUIREMENTS

In order to be considered responsive, a bidder must make good faith efforts to meet the goal for Disadvantaged Business Enterprise (DBE) participation in this contract. The bidder must comply with Paragraphs A and B below and submit all documentation with submittal of the bid. If the bidder fails to do so, its bid may be deemed non-responsive and may be rejected.

- A. Properly completing and signing Schedule A (Summary of DBE Participation). Schedule A is a list of all DBE subcontractors, their scope of work to be performed and dollar amount of participation of each DBE subcontractor.

ANY DBE(S) LISTED ON SCHEDULE A MUST BE DBE CERTIFIED BY THE ILLINOIS UNIFIED CERTIFICATION PROGRAM (IL UCP) AT THE TIME OF THE BID OPENING.

- B. Properly complete Schedule B (Confirmation of Proposed DBE Participation) of this Exhibit. Schedule B must list the name of the DBE subcontractor, a detailed description of DBE's scope of work, and dollar amount of participation of each, and only each, DBE that will participate in this contract. If the bidder is itself a DBE, the DBE bidder must indicate on Schedule B what scope of work its forces will actually perform outside of the work of any subcontractor, and the dollar amount of that work. If this amount does not satisfy the DBE goal, the DBE bidder must list the additional DBE subcontractor(s) that will satisfy the DBE goal, along with their scope of work and agreed upon subcontract amount(s).

DBE RESPONSIBILITY REQUIREMENTS

- A. DBE Joint Ventures

If the bidder is a DBE joint venture, a two-party signed joint venture agreement (Schedule C) must be submitted to Pace for Pace's approval along with your bid. This agreement must address the administrative, financial, and field responsibilities of each partner. The DBE participation must meet the criteria as set forth in the definitions in the following section "Calculating DBE Participation."

- B. Substitutions

The bidder cannot substitute any DBEs listed on Schedule A or C (if a joint venture) without prior written approval from Pace.

CALCULATING DBE PARTICIPATION

Pace will only count those DBEs that are certified by the IL UCP at the time of bid opening towards a Pace Contract goal.

A. Definitions

“Disadvantaged Business Enterprise” or “DBE” means a for-profit small business concern that meets all of the following criteria:

1. Is at least fifty-one percent (51%) owned by one or more individuals who are both socially and economically disadvantaged or, in the case of a corporation, in which fifty-one percent (51%) of the stock is owned by one or more such individuals
2. Whose management structure and daily business operations are controlled by one or more of the socially and economically disadvantaged individuals who own it
3. Is certified by the IL UCP at the time of bid opening

“Good Faith Efforts” means efforts to achieve a DBE goal which, by their scope, intensity, and appropriateness to the objective, can reasonably be expected to fulfill the program requirement. This definition is not intended to relieve the bidder of any of the responsiveness (or responsibility) requirements listed in SECTION B, *Disadvantaged Business Enterprise Compliance Requirements* of this Exhibit.

“Joint Venture” means an association of a DBE firm and one or more other firms to carry out a single, for-profit business enterprise, for which the parties combine their property, capital, efforts, skills and knowledge, and in which the DBE is responsible for a distinct, clearly defined portion of the work of the contract and whose share in the capital contribution, control, management, risks, and profits of the joint venture are commensurate with its ownership interest.

“Small Business concern” means with respect to firms seeking to participate as DBEs in DOT-assisted contracts, a small business concern as defined pursuant to Section 3 of the Small Business Act and Small Business Administration regulations implementing it (13 CFR Part 121) that also does not exceed the cap on average annual gross receipts specified in 49 CFR Part 26.65(b).

“Socially and Economically Disadvantaged” individual means any individual who is a citizen (or lawfully admitted permanent resident) of the United States and who is:

1. Any individual who Pace finds to be a socially and economically disadvantaged individual on a case-by-case basis.
2. Any individual in the following groups, members of which are presumed to be socially and economically disadvantaged:
 - a. *“Black Americans,”* which includes persons having origins in any of the Black racial groups of Africa;
 - b. *“Hispanic Americans,”* which includes persons of Mexican, Puerto Rican, Cuban, Dominican, Central or South American, or other Spanish or Portuguese culture or origin, regardless of race;
 - c. *“Native American,”* which includes persons who are American Indians, Eskimos, Aleuts, or Native Hawaiians;
 - d. *“Asian Pacific American,”* which includes persons whose origins are from Japan, China, Taiwan, Korea, Burma (Myanmar), Vietnam, Laos, Cambodia (Kampuchea), Thailand, Malaysia, Indonesia, the Philippines, Brunei, Samoa, Guam, the U.S. Trust Territories of the Pacific Islands (Republic of Palau), the Commonwealth of the Northern Marianas Island, Macao, Fiji, Tonga, Kiribati, Juvalu, Nauru, Federated States of Micronesia, or Hong Kong;
 - e. *“Subcontinent Asian American,”* which includes persons whose origins are from India, Pakistan, Bangladesh, Bhutan the Maldives Island, Nepal or Sri Lanka;
 - f. *“Women”;*
 - g. Any additional groups whose members are designated as socially and economically disadvantaged by the United States Small Business Administration (SBA), at such time as SBA designation becomes effective.

B. General Conditions/DBE Calculations

Pace will use the certification standards of Subpart D of *49 CFR Part 26* and the certification procedures of Subpart E of *49CFR Part 26* to determine the eligibility of firms to participate as DBEs in DOT-assisted contracts. To be certified as a DBE, a firm must meet all certification eligibility standards. Pace, Suburban Bus Division of the Regional Transportation Authority will make its certification decision based on the facts as a whole.

As a partner in the IL UCP, Pace can provide, upon request, a directory of IL UCP DBE firms. The directory will also be available electronically at www.Pacebus.com.

As required by 49 CFR Part 26.55, Pace counts DBE participation toward overall and contract goals as follows:

1. When a DBE participates in a contract, Pace counts only the value of the work actually performed by the DBE toward the DBE goal. Participation will only be credited in the DBE's area of specialization. Credit for work in other areas requires additional support documentation for each of those areas.
2. Pace counts the entire amount of that portion of a contract that is performed by the DBE's own forces. This includes the cost of supplies and materials obtained by the DBE for the work of the contract, including supplies purchased or equipment leased by the DBE (except supplies and equipment the DBE subcontractor purchases or leases from the Contractor or its affiliate).
3. Pace counts the entire amount of fees or commissions charged by a DBE firm for providing a bona fide service, such as professional, technical, consultant, or managerial services, or for providing bonds or insurance specifically required for the performance of a DOT-assisted contract, toward DBE goals, provided Pace determines the fee to be reasonable and not excessive as compared with fees customarily allowed for similar services.
4. When a DBE subcontracts part of the work of its contract to another firm, the value of the subcontracted work may be counted toward DBE goals only if the DBE's subcontractor is itself a DBE. Work that a DBE subcontracts to a non-DBE firm does not count toward DBE goals.
5. When a DBE performs as a participant in a joint venture, Pace counts a portion of the total dollar value of the contract equal to the distinct, clearly defined portion of the work of the contract that the DBE performs with its own forces toward DBE goals.
6. Pace counts expenditures to a DBE toward DBE goals only if the DBE is performing a commercially useful function on this contract.
 - a. A DBE performs a commercially useful function when it is responsible for execution of the work of the contract and is carrying out its responsibilities by actually performing, managing, and supervising the work involved. To perform a commercially useful function, the DBE must also be responsible, with respect to materials and supplies used on the contract, for negotiating price, determining quality and quantity, ordering the material, and installing (where applicable) and paying for the material itself. To determine whether a DBE is performing a commercially useful function, Pace, Suburban Bus Division of the Regional Transportation Authority must evaluate the amount of work subcontracted, industry practices, whether the amount the firm is to be paid under the contract is commensurate with the work it is actually performing and the DBE credit claimed for its performance of work, and other relevant factors.
 - b. A DBE does not perform a commercially useful function if its role is limited to that of an extra participant in a transaction, contract, or project through which funds are passed in order to obtain the appearance of DBE participation. In determining whether a DBE is such an extra participant, Pace, Suburban Bus Division of the Regional Transportation Authority must examine similar transactions particularly those in which DBEs do not participate.
 - c. If a DBE firm acting as a Contractor and/or as a subcontractor under this contract does not perform or exercise responsibility for at least thirty percent (30%) of the total cost of its contract with its own work force, or the DBE subcontracts a greater portion of the work of a contract than would be expected on the basis of normal industry practice for the type of work involved, Pace must presume that it is not performing a commercially useful function.
 - d. Pace uses the following factors in determining whether a DBE trucking company is performing a commercially useful function:
 - i. The DBE must be responsible for the management and supervision of the entire trucking operation for which it is responsible on a particular contract, and there cannot be a contrived arrangement for the purpose of meeting DBE goals;
 - ii. The DBE must itself own and operate at least one fully licensed, insured, and operational truck used on the contract;
 - iii. The DBE receives credit for the total value of the transportation services it provides on the contract using trucks it

- owns, insures, and operates using drivers it employs;
- iv. The DBE may lease trucks from another DBE firm, including an owner-operator who is certified as a DBE. The DBE who leases trucks from another DBE receives credit for the total value of the transportation services the lessee DBE provides on the contract;
 - v. The DBE may also lease trucks from a non-DBE firm, including an owner-operator. The DBE who leases trucks from a non-DBE is entitled to credit only for the fee or commission it receives as a result of the lease agreement. The DBE does not receive credit for the total value of the transportation services provided by the lessee, since these services are not provided by a DBE; and
 - vi. For purposes of this subparagraph (d), a lease must indicate that the DBE has exclusive use of and control over the truck. This does not preclude the leased truck from working for others during the term of the lease with the consent of the DBE, so long as the lease gives the DBE absolute priority for use of the leased truck. Leased trucks must display the name and identification number of the DBE.
- e. If a DBE is presumed not to be performing a commercially useful function as provided in these requirements, the DBE may present evidence to rebut this presumption. Pace may determine that the firm is performing a commercially useful function given the type of work involved and normal industry practices.
 - f. Pace's decisions on commercially useful function matters are subject to review by the Federal Transit Administration, but are not administratively appealable to United States Department of Transportation.
7. Pace counts expenditures with DBEs for materials or supplies toward DBE goals as provided in the following:
- a. If the materials or supplies are obtained from a DBE manufacturer, Pace, Suburban Bus Division of the Regional Transportation Authority counts 100 percent (100%) of the cost of the materials or supplies toward DBE goals;
 - b. For purposes of these requirements, a manufacturer is a firm that operates or maintains a factory or establishment that produces, on the premises, the materials, supplies, articles, or equipment required under the contract and of the general character described by the specifications;
 - c. If materials or supplies are purchased from a DBE regular dealer, Pace, Suburban Bus Division of the Regional Transportation Authority counts sixty percent (60%) of the cost of the materials or supplies toward DBE goals;
 - d. For purposes of these requirements, a regular dealer is a firm that owns, operates, or maintains a store, warehouse, or other establishment in which the materials, supplies, articles or equipment of the general character described by the specifications and required under the contract are bought, kept in stock, and regularly sold or leased to the public in the usual course of business.
 - i. To be a regular dealer, the firm must be an established, regular business that engages, as its principal business and under its own name, in the purchase and sale or lease of the products in question;
 - ii. A person may be a regular dealer in such bulk items as petroleum products, steel, cement, gravel, stone, or asphalt without owning, operating, or maintaining a place of business as provided in this paragraph if the person both owns and operates distribution equipment for the products. Any supplementing of regular dealer's own distribution equipment shall be by a long-term lease agreement and not on an ad hoc or contract-by-contract basis;
 - iii. Packagers, brokers, manufacturers' representatives, or other persons who arrange or expedite transactions are not regular dealers within the meaning of this paragraph;
 - iv. With respect to materials or supplies purchased from a DBE which is neither a manufacturer nor a regular dealer, Pace counts the entire amount of fees or commissions charged for assistance in the procurement of the materials and supplies, or fees or transportation charges for the delivery of materials or supplies required on a job site, toward DBE goals, provided Pace determines the fees to be reasonable and not excessive as compared with fees customarily allowed for similar service. Pace will not count any portion of the cost of the materials and supplies themselves toward DBE goals, however;

8. Pace will not count toward its overall goal the dollar value of work performed under a contract by a firm after it has ceased to be certified.
9. Pace will not count the participation of a DBE subcontractor toward the Contractor's DBE achievements or Pace's overall goal until the amount being counted toward the goal has been paid to the DBE.

GOOD FAITH EFFORTS

In order to be responsive, a bidder must make good faith efforts to meet Pace's DBE goal in either of two ways. The bidder must either 1) document how it will meet the full goal by completing and signing Schedule A or C (if a joint venture); or 2) document its attempt to meet the goal through detailed, corroborating evidence, i.e. demonstrate that it took *all necessary and reasonable steps* which, by their scope, intensity, and appropriateness to the objective, could reasonably be expected to obtain sufficient DBE participation, even if the bidder was not fully successful. Pace will make a fair and reasonable judgment whether a bidder that did not meet the goal made adequate good faith efforts. Pace will consider the quality, quantity, and intensity of the different kinds of efforts that the bidder/proposer made. The efforts employed by the bidder should be those that one would reasonably expect a bidder to take if the bidder were actively and aggressively trying to obtain DBE participation sufficient to meet the DBE contract goal. Mere *pro forma* efforts are not good faith efforts to meet the DBE contract requirements.

The following is a list of types of action that Pace will consider as part of the evaluation of the bidder's good faith efforts to obtain DBE participation. It is not intended to be a mandatory check list, or to be exclusive or exhaustive. Other factors or types of efforts may be relevant in appropriate cases:

- A. Soliciting through all reasonable and available means (e.g. attendance at pre-bid meetings, if applicable, advertising, and/or written notices) the interest of all certified DBEs who have the ability to perform the work of the contract. The bidder must solicit this interest within sufficient time to allow the DBEs to respond to the solicitation. The bidder must determine with certainty if the DBEs are interested by taking appropriate steps to follow up initial solicitations.
- B. Selecting portions of the work to be performed by DBEs in order to increase the likelihood that the DBE goals will be achieved. This includes, where appropriate, breaking out contract work items into economically feasible units to facilitate DBE participation, even when the bidder might otherwise prefer to perform these work items with its own forces.
- C. Providing interested DBEs with adequate information about the plans, specifications, and requirements of the contract in a timely manner to assist them in responding to a solicitation.
- D. Negotiating in Good Faith with interested DBEs
 1. It is the bidder's responsibility to make a portion of the work available to DBE subcontractors and suppliers and to select those portions of the work or material needs consistent with the available DBE subcontractors and suppliers, so as to facilitate DBE participation. Evidence of such negotiation includes:
 - a. the names, addresses, and telephone numbers of DBEs that were considered
 - b. a description of the information provided regarding the plans and specifications for the work selected for subcontracting
 - c. evidence as to why additional agreements could not be reached for DBEs to perform the work
 2. A bidder using good business judgment would consider a number of factors in negotiating with subcontractors, including DBE subcontractors, and would take into consideration a firm's price and capabilities, as well as contract goals. The fact that there may be some additional costs involved in finding and using DBEs, however, is not in itself sufficient reason for a bidder's failure to meet the contract DBE goal, as long as such costs are reasonable. Also, the ability or desire of a bidder to perform the work of a contract with its own organization does not relieve the bidder of the responsibility to make good faith efforts. Bidders are not, however, required to accept high quotes from DBEs if the price difference is excessive or unreasonable.
- E. Not rejecting DBEs as being unqualified without sound reasons based on a thorough investigation of their capabilities. The bidder's standing within the industry, membership in specific groups, organizations, or associations and political or social affiliations (for example, union vs. non-union employee status) are not legitimate causes for the rejection or non-solicitation of bids in the bidder's efforts to meet the project goal.
- F. Making efforts to assist interested DBEs in obtaining bonding, lines of credit, or insurance as required by Pace or the bidder.

- G. Making efforts to assist interested DBEs in obtaining necessary equipment, supplies, materials, or related assistance or services.
- H. Effectively using the services of available minority/women community organizations; minority/women contractors' groups; local, state, and federal minority/women business assistance offices, and other organizations as allowed on a case-by-case basis to provide assistance in the recruitment and placement of DBEs.

Pace will also take into account the performance of other bidders in meeting the contract goal. For example, when the apparent successful bidder fails to commit to the contract goal, but others commit to the goal, Pace will raise the question of whether, with additional reasonable efforts, the apparent successful bidder could have committed to the goal. If the apparent successful bidder fails to commit to the goal, but meets or exceeds the average DBE participation obtained by other bidders, Pace may view this, in conjunction with other factors, as evidence that the apparent successful bidder made good faith efforts.

The DBE Liaison Officer for Pace is responsible for determining whether a bidder has properly committed to meet the DBE goal and whether a bidder who has not committed to meeting the goal has documented good faith efforts in order to be responsive. Pace must be satisfied that all information is complete and accurate, and adequately documents the bidder's good faith efforts before Pace commits to the performance of the contract by the successful bidder.

RECONSIDERATION

In accordance with 49 CFR §26.53(d), if Pace determines that a bidder is not responsive because it has not committed to meeting the contract goal or has not documented sufficient good faith efforts, it will notify the bidder in writing, and the bidder will have five (5) business days after receipt of this notification to request administrative reconsideration. The bidder must make this request in writing to the following Pace Reconsideration Official:

General Counsel
Pace
550 W. Algonquin Road
Arlington Heights, IL 60005

The Reconsideration Official will not have played any role in the original determination that the bidder did not document sufficient good faith efforts.

As part of this Reconsideration, the bidder shall have the opportunity to provide written documentation or argument concerning the issue of whether it committed to meeting the contract goal or made adequate good faith efforts to do so. The bidder can also request in writing to meet in person with Pace's Reconsideration Official to discuss these issues; this request for a meeting must be submitted within five (5) business days after receipt of notification of non-compliance. Pace will send the bidder a written decision within ten (10) business days after its reconsideration request was received by Pace, Suburban Bus Division of the Regional Transportation Authority, explaining Pace's basis for the finding that the bidder did or did not meet the goal or did or did not make adequate good faith efforts to do so. The result of this reconsideration process is not administratively appealable to the United States Department of Transportation and Pace, Suburban Bus Division of the Regional Transportation Authority's decision shall be final.

DOCUMENTATION REQUIREMENTS

A. Documentation of Subcontracts and Subcontractor Agreements after Contract Award

Within thirty (30) days upon receipt of an executed purchase order and contract, the Contractor must submit to the DBE Liaison Officer at Pace copies of SIGNED contracts between the Contractor and the DBE company/companies listed on its original DBE Schedules A and B.

FAILURE TO PROVIDE THE SIGNED SUBCONTRACT(S) TO PACE WITHIN THE TIME FRAME REQUIRED SHALL CONSTITUTE A BREACH OF THIS CONTRACT, AND UPON SUCH BREACH, PACE MAY TERMINATE THIS CONTRACT AND/OR EXERCISE OTHER SANCTIONS, PENALTIES, OR REMEDIES AS ALLOWED BY LAW OR EQUITY, AND AS PACE DEEMS APPROPRIATE.

B. Documentation of Payments Made to DBE Firms

1. The Contractor must submit copies of the DBE’s monthly contract invoices including support documentation to the DBE Liaison Officer at the same time they are submitted to Pace Account Payable.
2. The Contractor must submit copies of the form illustrated below (including support documentation) to the DBE Liaison Officer on a quarterly basis. This form must be used in order to properly credit the Contractor’s progress in attaining the DBE goal.

SAMPLE ONLY – DO NOT COMPLETE

Subcontract or Name (Company)	Description of services/work/product performed	Committed Percentage (for this reporting quarter)	Committed Percentage (YTD)	Total paid to Sub (Current quarter)	YTD paid to Sub (From date of contract)
				\$	\$
				\$	\$
				\$	\$
				\$	\$
Total					\$

C. Pace may make on-site visits from time to time during the course of this contract to ensure compliance with the requirements set forth herein.

Pace may require verification of any commitment represented to us in connection with the Contractor’s use of DBE businesses in the performance of this contract. Pace reserves the right to review the certified payrolls for the Contractor and all contractors working on this contract.

Further, if problems should arise with respect to the Contractor’s subcontract with any DBEs, please contact Pace’s DBE Liaison Officer so that Pace may be apprised of all DBE issues.

D. Substitution or Termination of DBE Firms

The Contractor may not terminate a listed and approved DBE subcontractor or an approved substitute DBE firm without the prior written approval of Pace’s DBE Liaison Officer and Pace’s Project Manager. This includes, but is not limited to, instances in which a Contractor seeks to perform work originally designated for a DBE subcontractor with its own forces or those of an affiliate, a non-DBE firm, or with another DBE firm. The Contractor will have to show good cause in order to terminate the listed and approved DBE firm.

Good Cause includes the following circumstances:

1. The listed DBE subcontractor fails or refuses to execute a written contract;
2. The listed DBE subcontractor fails or refuses to perform work of its subcontract in a way consistent with normal industry standards. Provided, however, that good cause does not exist if the failure or refusal of the DBE subcontractor to perform its work on the subcontract results from the bad faith or discriminatory action of the Contractor;
3. The listed DBE subcontractor fails or refuses to meet the Contractor's reasonable, nondiscriminatory bond requirements;
4. The listed DBE subcontractor becomes bankrupt, insolvent, or exhibits credit unworthiness;
5. The listed DBE subcontractor is ineligible to work on public works projects because of suspension and debarment proceedings pursuant to 2 CFR Parts 180, 215, and 1200 or applicable state law;
6. Pace's DBE Liaison Office has determined that the listed DBE subcontractor is not a responsible Contractor;
7. The listed DBE subcontractor voluntarily withdraws from the project and provides to you written notice of its withdrawal;
8. The listed DBE is ineligible to receive DBE credit for the type of work required;
9. A DBE owner dies or becomes disabled with the result that the listed DBE contractor is unable to complete its work on the contract.
10. Other documented good cause that Pace's DBE Liaison Office determines compels the termination of the DBE subcontractor. Provided that good cause does not exist if;
 - The Contractor seeks to terminate a DBE it relied upon to obtain the contract so that the Contractor can self-perform the work for which the DBE subcontractor was engaged; or
 - So that the Contractor can substitute another DBE or non-DBE subcontractor after contract award.

Before the Contractor seeks to terminate and/or substitute a DBE subcontractor, the Contractor must give notice in writing to the DBE subcontractor, with a copy to Pace's Project Manager and Pace's DBE Liaison Officer, of its intent to request to terminate and/or substitute, and the reason for the request. The DBE firm will have five (5) working days (or less if required by public necessity) to respond to the Contractor's notice and advise the DBE Liaison Officer and the Contractor of the reasons, if any, why it objects to the proposed termination of its subcontract and why Pace should not approve the Contractor's action.

In the situation where the DBE's work scope has been modified by Pace, the Contractor must immediately notify Pace's Project Manager and Pace's DBE Liaison Officer to discuss a revised "Commitment to DBE Participation".

These provisions apply to post-award terminations and pre-award deletions of, or substitutions for, DBE firms put forward by offerors in negotiated procurements.

E. Inspections and Records

1. Pace may, with or without notice, periodically conduct on-site visits of any contract performance site or the place of business of any Contractor or DBE subcontractor from time to time during the course of a contract to ensure compliance with the requirements set forth in Pace's contracts. The DBE department may be assisted by other Pace staff, and shall be entitled to reasonable access to facilities, personnel, and records related to the compliance plan.
2. Pace may require verification of any commitment represented to us in connection with the Contractor's use of DBE businesses in the performance of this contract.
3. Pace reserves the right to review the certified payrolls, performance/payment records concerning subcontractors' payroll records, tax returns and records, and books of accounts for the Contractor and all subcontractors working on any Pace, Suburban Bus Division of the Regional Transportation Authority contract. Full access shall be granted upon 48-hours' notice by Pace, Suburban Bus Division of the Regional Transportation Authority or any duly authorized representative thereof or any law enforcement authority.

F. Change Orders

The contract specific DBE goals applicable to a contract may also be applicable to change orders or contract modifications, when the proposed change order work relates to the services provided by the DBE subcontractor.

G. Non-Compliance and Sanctions

1. Determination of Non-Compliance

- a. It will be the responsibility of Pace's DBE Liaison Officer to monitor the compliance plan, as well as the fulfillment of any special conditions, work order goals, or other obligations of the contract as it pertains to the DBE program and DBE goals.
- b. Prior to contract closeout, the DBE Liaison Officer shall determine whether a Contractor has complied with the obligations under its compliance plan and other related requirements. The Contractor has the burden of proving compliance with all obligations and requirements
- c. If the Contractor fails to fulfill the requirements of the compliance plan or other compliance-related contractual obligation, Pace will notify the Contractor of the deficiencies. Following notification, the Contractor shall have sixty (60) days to cure the deficiencies. If the deficiencies are not cured, Pace shall make a determination of non-compliance and recommend the imposition of sanctions.

2. Sanctions for Non-Compliance

- a. Sanctions for non-compliance may include, but are not limited to, the following:
 - i. Withholding of payments under the contract;
 - ii. Recommendation not to exercise contract renewal option, if any;
 - iii. Termination of the contract
 - iv. Debarment from future business with Pace, Suburban Bus Division of the Regional Transportation Authority

DBE Schedule A Checklist

A completed and signed Schedule A consists of the following elements:

- 1. Contractor
- 2. Name of Project
- 3. Phone
- 4. Email
- 5. IFB/RFP Number
- 6. **TOTAL** Estimated Contract Amount
- 7. Projected DATES
- 8. Title of Affiant (Contractor Duly Authorized Representative)
- 9. Contractor Company Name
- 10. DBE Participant(s) Company Name(s)
- 11. Scope of Work / Description (In Detail) for Each DBE Participant
- 12. Dollar Amount of Each DBE Contract - **Total** from each DBE's Schedule B)
- 13. Net DBE Credit *60% credited for materials and supplies (see notation below if applicable)
- 14. TOTAL Dollar Amount for All DBE Contracts Listed
- 15. TOTAL Net DBE Credit (If applicable)
- 16. Printed or Typed Name of Contractor 's Affiant
- 17. Title of Affiant
- 18. Signature of Affiant
- 19. Date Signed

Note: This Checklist serves solely as a reference guide to assist the Bidder in adequately submitting all required documents

Instructions for NET DBE CREDIT

If the materials or supplies are obtained from a DBE manufacturer, count 100 percent (100%) of the cost of the materials or supplies toward DBE goals.

A **manufacturer** is a firm that operates or maintains a factory or establishment that produces, on the premises, the materials, supplies, articles, or equipment required under the contract and of the general character described by the specifications.

If the materials or supplies are purchased from a DBE regular dealer, count 60 percent (60%) of the cost of the materials or supplies toward DBE goals.

A regular **dealer** is a firm that owns, operates, or maintains a store, warehouse, or other establishment in which the materials, supplies, articles or equipment of the general character described by the specifications and required under the contract are bought, kept in stock, and regularly sold or leased to the public in the usual course of business.

Pace will not count the participation of a DBE subcontractor toward a contractor's final compliance with its DBE obligations on a contract until the amount being counted has actually been paid to the DBE.

SCHEDULE A

CONTRACTOR - SUMMARY OF DBE PARTICIPATION AS SUBCONTRACTOR, SUPPLIER AND/OR CONSULTANT

NAME OF CONTRACTOR: (1) _____ NAME OF PROJECT: (2) _____

PHONE # (3) _____ EMAIL: (4) _____ IFB/RFP NUMBER: (5) _____

TOTAL ESTIMATED CONTRACT AMOUNT: (6) \$ _____ PROJECTED BEGINNING/ENDING DATES OF WORK: (7) _____

In connection with the above captioned contract, I HEREBY DECLARE AND AFFIRM that I am the (8) _____) and duly authorized representative of (9) _____

(Title of Affiant)

(Name of Contractor)

and that I have personally reviewed the material and facts set forth in and submitted with the attached Disadvantaged Business Enterprises (DBE) Schedules for each DBE. Listed below is/are the agreement(s) that correspond(s) with the Schedule B submitted by **each** DBE and **listed separately** for **each** DBE participating on the above mentioned contract:

NAME OF DBE SUBCONTRACTOR (10)	SCOPE OF WORK TO BE PERFORMED (11)	AGREED SUBCONTRACT PRICE (12)	NET DBE CREDIT * (13)
NOTE: PRICES REPRESENTED ON THIS PAGE SHOULD ACCURATELY REFLECT AGREEMENT BETWEEN CONTRACTOR AND SUBCONTRACTOR.		TOTAL DBE (14) CONTRACT AMOUNT \$	
* ONLY 60% OF AGREED SUBCONTRACT PRICE MAY BE CREDITED FOR MATERIALS AND SUPPLIES LIST ONLY BONA FIDE DBE OWNED & CONTROLLED FIRMS THAT WILL PARTICIPATE IN THIS CONTRACT.		TOTAL NET (15) DBE CREDIT \$	

AFFIDAVIT OF CONTRACTOR – *failure to submit this form without a signature will result in the bid being rejected in its entirety*

The undersigned will enter into formal agreements with all listed DBE firms for work as indicated by this Schedule A and accompanying Schedules, and will enter into such agreements within thirty (30) calendar days after receipt of the contract executed by Pace. In the event the Contractor cannot meet said thirty (30) day schedule, it must provide a written explanation for the delay and an estimate date by which the written agreement will be completed.

I understand that if I knowingly provide incorrect information or false statements or fail to comply with contract DBE requirements that Pace has an obligation (49 CFR 29.17(B)) to inform the U.S. Department of Transportation who may then initiate actions which would prohibit the Contractor from participation in future government contracts and may result in conviction for a Class 2 felony, including a penalty for one and a half times the value of the contract. Any substitutions of the above-named subcontractors requires prior written approval from Pace.

I do solemnly declare and affirm under penalty of perjury that the contents of the foregoing document are true and correct, and no material facts have been omitted, and that I am authorized on behalf of the Contractor to make this affidavit.

(Name of Contractor's Affiant – Print or Type)

Title of Affiant

(Signature)

(Date)

DBE Schedule B Checklist

**Letter of Intent from DBE to Perform as Subcontractor, Supplier
and/or Consultant**

A completed and signed Schedule B consists of the following elements:

- 1. IFB/RFP Number
- 2. Name of Project
- 3. DBE Participant Company Name
- 4. Contractor Company Name
- 5. DBE Participant Address
- 6. DBE Participant Phone Number
- 7. DBE Participant Email Address
- 8. Date of IL UCP DBE Certification Letter
- 9. Description/Type of Work (In Detail)
- 10. Quantity/Unit Price, if Applicable
- 11. Dollar Amount of DBE Contract Total Sum Amount for Work or Extended Price for individual Quantity Items) **NOTE: Specify Total Value**
- 12. Grand Total of above Amount(s) and/or Extended Price(s)
- 13. Phase (if Applicable) in Which Above-Described Work Will Be Performed

Subcontracting Levels

- 14. % *___ of the dollar amount of the DBE's Subcontract will be sublet to DBE Contractors.
- 15. % *___ of the dollar amount of the DBE's Subcontract will be sublet to non-DBE Contractors.
 - * *This is to disclose the % of above-named DBE participant's work to be further subcontracted to others (DBE or non-DBE), not the DBE Participant's % of work on the Contractor's contract.*
 - * *% is to be filled in with a Zero (0) if the above-named DBE Participant will not be further subcontracting any of the work described in this Schedule B*
- 16. Explanation and Description of the Work To Be Sublet (if applicable)
- 17. Printed Name/Title of Owner, President or Authorized Agent of DBE Company
- 18. Signature of Owner, President or Authorized Agent of DBE Company
- 19. Date Signed

If proposing to perform as a DBE/non-DBE Joint Venture:

- 20. Completed SCHEDULE C must be attached

Note: This Checklist serves solely as a reference guide to assist the Bidder in adequately submitting all required documents.

SCHEDULE B
AFFIDAVIT OF DBE SUBCONTRACTOR

Subcontracting Levels

(14) % _____ of the dollar amount of the DBE's subcontract will be sublet to **DBE Subcontractors**.

(15) % _____ of the dollar amount of the DBE's subcontract will be sublet to **non-DBE Subcontractors**.

NOTICE: IF THE DBE WILL NOT BE SUBCONTRACTING ANY OF THE WORK DESCRIBED IN THIS SCHEDULE, A ZERO (0) MUST BE SHOWN IN EACH BLANK ABOVE.

IF **ANY** DOLLAR AMOUNT OF THE DBE's SCOPE OF WORK WILL BE SUBLET, A BRIEF EXPLANATION AND DESCRIPTION OF THE WORK TO BE SUBLET MUST BE LISTED BELOW: (16)

NOTICE: Any misrepresentation regarding the status of a person or an entity in order to qualify for DBE status may result in conviction for a Class 2 felony, including a penalty for one and a half times the value of the contract. Material misrepresentation on any matter will also be grounds for terminating any contract which may be awarded, and for initiating action under federal or state laws concerning false statements.

The undersigned will enter into a formal written agreement for the above work with the Contractor conditioned upon their execution of a contract with Pace, and will do so within thirty (30) calendar days of their receipt of a signed contract from Pace.

I further understand that any willful falsification, fraudulent statement, or misrepresentation will result in appropriate sanctions, which may include debarment and/or prosecution under applicable State and Federal laws.

(17) _____
Print - Name and Title

(18) _____
Signature of Owner, President or Authorized Agent of DBE

(19) _____
Date

Pursuant to 49 CFR §26.13(b), each subcontract the contractor signs with a subcontractor must include the following assurance:

{ The contractor, sub recipient or subcontractor shall not discriminate on the basis of race, color, national origin, or sex in the performance of this contract. The contractor shall carry out applicable requirements of 49 CFR Part 26 in the award and administration of DOT-assisted contracts. Failure by the contractor to carry out these requirements is a material breach of this contract, which may result in the termination of this contract or such other remedy as Pace deems appropriate. }

Pursuant to 49 CFR §26.27, Pace encourages you to utilize financial institutions owned and controlled by socially and economically disadvantaged individuals within your community.

SCHEDULE C
AFFIDAVIT OF DBE/NON-DBE JOINT VENTURE

This Schedule C need not be submitted if all joint ventures are DBEs. In such a case, however, the written joint venture agreement and a copy of the current IL UCP Letter of Certification for each DBE must be submitted.

ALL INFORMATION REQUESTED BY THIS SCHEDULE MUST BE ANSWERED IN THE SPACES PROVIDED BY JOINT VENTURERS AT ANY TIER. ADDITIONAL SHEETS MAY BE ATTACHED.

I. Name of joint venture: _____

Address of joint venture: _____
Street City State Zip

Phone number of joint venture: _____

II. Identify each non-DBE venture(s): _____

Name of Firm: _____

Address: _____
Street City State Zip

Phone: _____

Contact person for matters concerning DBE compliance: _____

III. Identify each DBE venturer(s): _____

Name of Firm: _____

Address: _____
Street City State Zip

Phone: _____

Contact person for matters concerning DBE compliance: _____

IV. Describe the role(s) of the DBE venturer(s) in the joint venture:

V. Attach a copy of the joint venture agreement. In order to demonstrate the DBE venturer's share in the ownership, control management responsibilities, risks and profits of the joint venture, the proposed joint venture agreement must include specific details related to: (1) the contributions of capital and equipment; (2) work items to be performed by the DBE's own forces, (3) work items to be performed under the supervision of the DBE venturer; and (4) the commitment of management, supervisory and operative personnel employed by the DBE to be dedicated to the performance of the project.

VI. Attach a copy of the current IL UCP Letter of Certification for each DBE joint venturer.

VII. Ownership of the Joint Venture:

A. What is the percentage(s) of DBE ownership in the joint venture?

DBE ownership percentage(s): _____

Non-DBE ownership percentage(s): _____

SCHEDULE C
AFFIDAVIT OF DBE/NON-DBE JOINT VENTURE

VII. Ownership of the Joint Venture *(continued)*:

A. Specify DBE/non-DBE percentages for each of the following (provide narrative descriptions and other detail as applicable):

1. Sharing of profit and loss: _____

2. Capital contributions: _____

(a) Dollar amounts of initial contribution: _____

(b) Dollar amounts of anticipated on-going contributions: _____

3. Contributions of equipment *(specify types, quality and quantities of equipment to be provided by each venturer)*:

4. Other applicable ownership interests, including ownership options or other agreements, which restrict or limit ownership and/or control:

5. **Provide copies of all written agreements between venturers concerning this project.**

6. Identify each current Pace contract and each contract completed during the past two (2) years by either of the joint venture partners participating in this joint venture:

VIII. Control of and Participation in the Joint Venture. Identify by name and firm those individuals who are, or will be, responsible for and have the authority to engage in the following management functions and policy decisions. (Indicate any limitations to their authority such as dollar limits and co-signatory requirements.):

A. Joint venture check signing:

B. Authority to enter contracts on behalf of the joint venture:

SCHEDULE C
AFFIDAVIT OF DBE/NON-DBE JOINT VENTURE

C. Signing, co-signing and/or collateralizing loans:

D. Acquisition of lines of credit:

E. Acquisition and indemnification of payment and performance bonds:

F. Negotiating and signing labor agreements:

G. Management of contract performance. *(Identify by name and firm only):*

1. Supervision of field operations: _____

2. Major purchases: _____

3. Estimating: _____

4. Estimating: _____

IX. Financial Controls of Joint Venture:

A. Which firm and/or individual will be responsible for keeping the books of account?

B. Identify the "managing partner," if any, and describe the means and measure of their compensation:

SCHEDULE C
AFFIDAVIT OF DBE/NON-DBE JOINT VENTURE

C. What authority does each venturer have to commit or obligate the other to insurance and bonding companies, financing institutions, suppliers, subcontractors, and/or other parties participating in the performance of this contract or the work of this

X. State the approximate number of personnel (by trade) needed to perform the joint venture's work under this contract. Indicate whether they will be employees of the majority firm, DBE firm, or the joint venture.

Trade	Non-DBE Firm (number)	DBE (number)	Joint Venture (number)

Professional

Administrative/Clerical

Unskilled Labor

If any personnel proposed for this project will be employees of the joint venture:

A. Are any proposed joint venture employees currently employed by either venture? _____
Employed by non-DBE (number): _____ Employed by DBE: _____

B. Identify by name and firm the individual who will be responsible for joint venture hiring:

XI. Please state any material facts and additional information pertinent to the control and structure of this joint venture:

The undersigned affirm that the foregoing statements are correct and include all material information necessary to identify and explain the terms and operations of our joint venture and the intended participation of each venturer in the undertaking. Further, the undersigned covenant and agree, under which work is done for Pace by the venturers, to provide to Pace current, complete and accurate information regarding actual joint venture work and the payment therefore, and any proposed changes to any provision of the joint venture, or those of each venturer relevant to the joint venture by authorized representatives of Pace, its Inspector General or any of its funding agencies.

Any misrepresentation regarding the status of a person or an entity in order to qualify for DBE status may result in conviction for a Class 2 felony, including a penalty for one and a half times the value of the contract. Material misrepresentation on any matter will also be grounds for terminating any contract which may be awarded, and for initiating action under federal or state laws concerning false statements.

NOTE: *If, after filing this Schedule C and before the completion of the joint venture's work on the project, there is any change in the information submitted, the joint venture must inform the DBE Liaison Officer directly in writing or through the contractor if the joint venture is a subcontractor.*

Name of DBE Partner Firm

Name of Non-DBE Partner Firm

Signature of Affiant

Signature of Affiant

Name and Title of Affiant (Type of Print)

Name and Title of Affiant (Type of Print)

Date

Date

- 13. Disclosures: The Contractor shall not use or disclose any data, designs or other information belonging to or supplied by or on behalf of Pace, unless expressly authorized in writing by Pace. Upon Pace's request, such data, designs or other information and any copies thereof shall be returned to Pace. Where Pace's data, designs or other information are furnished to the Contractor's suppliers for procurement of supplies by the Contractor for use in the performance of Pace Contracts, the Contractor shall insert the substance of this provision in its Contract.
- 14. Conflict of Interest: Members of the Board, officers and employees of Pace, their spouses, their children, their parents, their brothers and sisters and their children, are prohibited from having or acquiring any Contract or any direct pecuniary interest in any Contract which will be wholly or partially performed by the payment of funds or the transfer of property of Pace in accordance with Section 4.03 of the Pace Regulations Governing Public Bidding (Ordinance SBD 19-59).
- 15. Conflict In Provisions: In the event of a conflict between any of the terms and conditions contained in the base Contract and its referenced exhibits, the base Contract provisions shall apply unless otherwise provided for.
- 16. Trade Names: In cases where an item is identified in these Contract documents by a manufacturer's name, trade name, catalog number or reference, it is understood that the Contractor shall furnish the item so identified or shall furnish an "equal" unless specified elsewhere in the bid documents. The specific article, equipment or material mentioned shall be understood as establishing the type, function and minimum standard of design, efficiency, quality and performance desired and shall not be construed in such a manner as to exclude manufacturer's products of comparable design, efficiency, quality and performance. Bid quotations on other makes or catalog numbers will be considered for current or future purchases provided the Contractor clearly states that an "equal" is proposed and he furnishes sufficient information with his bid to determine compliance.
- 17. Warranties: The following warranty will apply unless otherwise provided for in the Contract documents. The Contractor warrants that articles or work products delivered hereunder shall be free from defects of material and workmanship and that all products furnished will conform to samples, specifications and/or drawings submitted as may be applicable, and are fit for the purpose for which purchased. The warranty period shall be for one (1) year from the date of delivery or date of final acceptance whichever is later. Pace may return any nonconforming or defective items or work products to the Contractor or require correction or replacement of the item at the time the defect is discovered, all at the Contractor's risk and expense. Acceptance of items or work products by Pace or payment therefore, shall not relieve the Contractor of his responsibilities hereunder.
- 18. Approximate Quantities and Line Items: Pace may accept and make award based on less than all of the items or for less than all of the units indicated under any given item, unless the bidder qualifies the bid by specific limitations or unless otherwise provided for in the solicitation. Bids may be submitted for quantities less than those specified. Pace reserves the right to make an award on any item for a quantity less than the quantity offered, at the unit prices offered, unless the bidder specifies otherwise in the bid. Where approximate quantities are stated, the unit prices quoted in the bid will apply regardless of whether the actual quantities are greater or lesser than the assumed quantities, the stated total notwithstanding.
- 19. Retention of Records: Unless otherwise specified elsewhere in the Contract, the Contractor shall maintain all records produced under the Contract, including records to support actual time and costs incurred, for a minimum period of five (5) years after completion of the Contract. All records maintained under the Contract shall be subject to inspection and audit by Pace and/or its designated agent upon reasonable notice to the Contractor.
- 20. Bid Protest Procedures

SECTION I

- A. Pace will hear and consider a bona fide bid protest regarding its procurement actions in accordance with the following procedures. Due to the significantly reduced role of FTA in bid protests, as described in Section II, it is anticipated that the majority of all protests will be evaluated and finally decided by Pace. Accordingly, Pace intends to provide a thorough review of all bona fide bid protests. Pace's primary concern, however, is the timely procurement of needed capital equipment, supplies or services. It does not intend to allow the filing of bid protests to unnecessarily delay the procurement process, especially if the protest involved is vexatious or frivolous in nature.

Notwithstanding the availability of these protest procedures, any interested party is encouraged to exhaust all methods described in the Contract Documents of resolving a procurement issue before filing a formal protest with Pace. In its consideration of a bid protest, Pace reserves the right to give due consideration to the good faith efforts of the protestor to resolve the issue involved through informal methods.

B. Definitions

For purposes of this section

- 1. The term "days" refers to working days of Pace
- 2. The term "interested party" means any person (a) who is an actual bidder/proposer or prospective bidder/proposer in the procurement involved, and (b) whose direct economic interest would be affected by the award of the Contract or by a failure to award the Contract

C. Submission of Protests

Any interested party may file a bid protest with Pace on the basis that Pace has failed to comply with applicable Federal or State law or with Pace's Procurement Regulations. The protest must be filed in accordance with the timing requirements set forth in subsection D of this section, and must include:

- 1. The name and address of the protestor
- 2. The number of the Contract solicitation
- 3. A statement of the grounds for the protest, and in particular the Federal or State law or Authority Regulation alleged to have been violated; this statement should be accompanied by any supporting documentation the protesting party desires Pace to consider in making its decision

Protests should be submitted to: Chief Procurement Officer
 Pace
 550 W. Algonquin Road
 Arlington Heights, IL 60005

D. Types of Protests and Timing

The requirement for timely filing of a bid protest with Pace will depend upon the type of protests involved. Pace will consider the following three types of protests by interested parties.

1. Protests regarding solicitation

Any bid protest regarding the solicitation by Pace must be filed no later than **five (5) days** before the opening of bids/closing date of the Request for Proposal. Any protest filed after that date which raises issues regarding the solicitation will not be considered by Pace.

This type of protest would include any claim that the solicitation contained exclusionary or discriminatory specifications, any challenge to the basis of award, or any claim that the solicitation documents or the solicitation process violated applicable Federal or State law, or that Pace failed to follow its Procurement Regulations in the solicitation of bids/proposals.

2. Protests regarding bid evaluation (Invitation for Bids)

Any bid protest regarding the evaluation of bids, submitted in response to an Invitation for Bid (IFB) issued by Pace, must be filed with Pace no later than **fifteen (15) days** after the public opening of bids. Any protest filed after such date which raises issues regarding the IFB evaluation will not be considered by Pace.

This type of protest would include any challenge to determinations by Pace of the responsiveness of a bid or the responsibility of a bidder, or any claim that the evaluation of bids violated Federal or State law or Pace's Procurement Regulations.

3. Protests regarding proposal evaluation (Request for Proposals)

The Request for Proposal (RFP) evaluation process, and all evaluation materials associated with this process, shall be considered confidential until final award of the Contract is made. Therefore, any protest regarding the evaluation of proposals, submitted in response to an RFP issued by Pace, must be filed with Pace no later than 15 days after the date of Contract award. Any protest filed after such date which raises issues regarding the RFP evaluation will not be considered.

This type of protest would include any challenge to determinations by Pace of the responsiveness of a proposal or the responsibility of a proposer, or any claim that the evaluation of proposals violated Federal or State law or Pace's Procurement Regulations.

4. Protests Regarding Award of Contract

Any protest regarding the award of the Contract must be filed no later than **fifteen (15) days** after the date of award. Any protest regarding the award of the Contract filed after that date will not be considered by Pace.

This type of protest will only be entertained by Pace if the protestor is able to demonstrate that the party awarded the Contract fraudulently represented itself as a responsible bidder or that Pace violated Federal or State law or its Procurement Regulations in the award of the Contract.

E. Pace Response

1. Types of Protests

Pace will notify the protestor upon timely receipt of a bid protest and may, where appropriate, request additional information from the protestor. Pace may, in its discretion, meet with the protestor to review the matters raised by the protest. Pace's consideration of the particular types of protests will, except as otherwise provided in Paragraph 2 of this subsection, be in accordance with the following provisions:

a. Protests regarding solicitation

Upon receipt of a timely filed protest regarding the solicitation, Pace will postpone the opening of bids until resolution of the protest. No additional bids will be accepted during the period of postponement.

If the protest regarding the solicitation involves a claim of unduly restrictive or exclusionary specifications, Pace will, in evaluating the protest, consider both the specific need of Pace for the feature or item challenged and whether competition is negatively impacted by including the specification regarding that feature or item. If Pace determines that such feature or item was included in the specification in order to meet justified and valid transit needs of Pace, and was not unduly restrictive of competition or designed to exclude a particular competitor, then Pace will have grounds to deny the protest.

b. Protest regarding bid evaluation (Invitation for Bids)

Upon receipt of a timely filed protest regarding the evaluation of bids, submitted in response to an Invitation for Bid (IFB) issued by Pace, Pace will suspend its evaluation, or award, of any or all bids submitted until resolution of the protest if Pace determines that the protestor has established that there is substantial evidence that there are doubts regarding the responsiveness of a bid or the responsibility of a bidder or regarding Pace's compliance with Federal or State law or its Procurement Regulations.

c. Protest regarding proposal evaluation (Request for Proposals)

Upon receipt of a timely filed protest regarding the evaluation of proposals, submitted in response to an Request for Proposal (RFP) issued by Pace, Pace will issue a stop work order, if necessary, until the resolution of the protest if Pace determines that the protestor has established that there is substantial evidence that there are doubts regarding the responsiveness of a proposal or the responsibility of a proposer or regarding Pace's compliance with Federal or State law or its Procurement Regulations.

d. Protests after award

Upon receipt of a timely filed protest regarding the award of a Contract, Pace will issue a stop work order, if necessary, until the resolution of the protest if Pace determines that the protestor has established a **Prima facie** case that the Contract was awarded fraudulently or in violation of Federal or State law or Pace's Procurement Regulations.

2. Decisions by Pace

As indicated above, in most instances Pace will suspend the procurement process upon receipt of a bona fide bid protest. However, Pace reserves the right, notwithstanding the pendency of a protest, to proceed with the appropriate action in the procurement process or under the Contract in the following cases:

- a. where the item to be procured is urgently required
- b. where Pace determines that the protest was vexatious or frivolous
- c. where delivery or performance will be unduly delayed, or other undue harm will occur, by failure to make the award promptly

After review of a bid protest submitted under this section, Pace will issue a written decision on the basis of the information provided by the protestor, the results of any meetings with the protestor, and Pace's own investigation. If the protest is upheld, Pace will take appropriate action to correct the procurement process and protect the rights of the protestor, including re-solicitation of bids/proposals, revised evaluation of bids/proposals or Pace determinations, or termination of the Contract. If the protest is denied, Pace will lift any suspension imposed and proceed with the procurement process or the Contract, as the case may be.

The availability of review of bid protests by FTA is described in Section II. As noted in that section, under FTA's revised procurement guidelines the role of the Federal government in bid protest review is quite limited.

SECTION II – FTA BID PROTEST PROCEDURE

Under Circular 4220.1F, FTA has substantially limited its review of bid protests recognizing that most protest issues are best resolved at the State or Local level. FTA will now only accept protests alleging that: Pace failed to have written protest procedures; or, Pace violated their own protest procedures.

If a protest is brought before FTA on either of these allegations, the only remedy recognized by FTA under Circular 4220.1F is to require Pace to follow its own protest procedures. FTA does not have the right to change Pace's substantive decision by substituting FTA's judgment for that of Pace.

Any protest to FTA must be filed in accordance with the requirements contained in FTA Circular 4220.1F and may only be made by an "interested party" which FTA has defined as "an actual or prospective bidder or offerer whose direct economic interest would be affected by the award of the Contract or by failure to award the Contract."

No protest may be filed with FTA later than five days after a final decision under Pace's procedure. As used in the preceding sentence, "filed" refers to the date of receipt by FTA and "days" refers to working days of the Federal Government.

Any alleged violation of a specified Federal requirement that provides an applicable complaint procedure shall be submitted and processed in accordance with the applicable Federal regulations instead of the requirements of FTA Circular 4220.1F. For example, see the Buy America Requirements, 40 C.F.R. Part 661 (Section 661.15); Participation of Minority Business Enterprises in Department of Transportation Program, 49 C.F.R. Section 26.107.

21. Illinois Freedom of Information Act (FOIA)

As a government agency, Pace is subject to the Illinois Freedom of Information Act (FOIA) or 5 ILCS 140/1, et. seq. as amended. Therefore, the contents of this Request for Proposals (RFP) or Invitation for Bids (IFB) and the Contractor's proposal or bid submitted in response to this RFP or IFB are subject to the Illinois FOIA statutes. However, there are various items that may be exempt, which include but are not limited to trade secrets or commercial/financial information that are proprietary, privileged, or confidential, or where disclosure of the same would result in competitive harm (refer to Section 4002 of the Technology Advancement and Development Act and to Section 7 of the Illinois Freedom of Information Act). If any such proprietary, privileged, or confidential information or data is included in the Contractor's proposal or bid, each page that contains this information or data should be marked as such (e.g., "Proprietary and Competition Sensitive") in order to indicate your claim to an exemption provided in the Illinois FOIA.

It is Pace's sole right and responsibility, however, to make the determination whether these items are exempt or not exempt under the Illinois FOIA statutes.

22. Dispute Resolution:

- a. Governing Law - This contract will be governed by and construed in accordance with the laws of the State of Illinois.
- b. Notice of Dispute and Negotiation - Either party may initiate a dispute by sending notice of a dispute to the other party. Once initiated, the parties shall attempt to promptly resolve the dispute through good faith negotiations.
- c. Performance During Dispute - Unless otherwise directed by Pace's authorized representative, contractor shall continue performance under this contract while matters in dispute are being resolved.
- d. Litigation, Venue and Jurisdiction - If the dispute is not resolved within fourteen (14) days after receipt of a notice of dispute, either party may then submit the dispute to an Illinois court of competent jurisdiction. The parties agree to submit to the exclusive jurisdiction of the Illinois courts over any claim or matter arising under or in connection with this contract.

SECTION C – FTA/IDOT/RTA REQUIREMENTS

U.S. DEPARTMENT OF TRANSPORTATION (DOT)
FEDERAL TRANSIT ADMINISTRATION (FTA)
ILLINOIS DEPARTMENT OF TRANSPORTATION (IDOT)
AND THE REGIONAL TRANSPORTATION AUTHORITY (RTA)

The following terms and conditions are incorporated herein by reference and made a part of any Contract(s) issued as a result of a Pace Request for Quotation, Invitation for Bid or Request for Proposal.

FTA Requirements

1. **Fly America Requirements:** The Fly America requirements apply to all Contracts greater than \$3,000 which include the transportation of persons or property, by air, between a place in the U.S. and a place outside the U.S., or between places outside the U.S. The Contractor agrees to comply with 49 U.S.C. 40118 (the “Fly America” Act) in accordance with the General Services Administration’s regulations at 41 CFR Part 301-10, which provide that recipients and sub-recipients of Federal funds and their Contractors are required to use U.S. Flag air carriers for U.S. Government-financed international air travel and transportation of their personal effects or property, to the extent such service is available, unless travel by foreign air carrier is a matter of necessity, as defined by the Fly America Act. The Contractor shall submit, if a foreign air carrier was used, an appropriate certification or memorandum adequately explaining why service by a U.S. flag air carrier was not available or why it was necessary to use a foreign air carrier and shall, in any event, provide a certificate of compliance with the Fly America requirements. The Contractor agrees to include the requirements of this section in all subcontracts that may involve international air transportation.

2. **Surface Transportation Assistance Act/Buy America:** The Buy America requirements apply to the following types of Contracts: Construction Contracts and Acquisition of Goods or Rolling Stock (valued at more than \$150,000). The Buy America requirements flow down from FTA recipients and sub-recipients to first tier Contractors, who are responsible for ensuring that lower tier Contractors and subcontractors are in compliance. The \$150,000 threshold applies only to the grantee’s (Pace’s) Contracts, subcontracts under that amount are subject to Buy America.
 - A. Pursuant to Section 165.a and 165.b of the Surface Transportation Assistance Act of 1982, the Contractor acknowledges that federal funds shall not be appropriated or utilized for any Contract awarded pursuant to this bid unless steel, cement and manufactured products used in such projects are produced in the United States; provided however, that the foregoing provision shall not apply where the Secretary of Transportation has made one of the following determinations:
 - (1) That the application of the foregoing provision would be inconsistent with the public interest
 - (2) That such materials and products are not produced in the United States in sufficient and reasonably available quantities and of a satisfactory quality
 - (3) In the case of the procurement of bus and other rolling stock (including train control, communication, and traction power equipment), that (a) the cost of components which are produced in the United States is more than 60% of the vehicle or equipment described in this paragraph, and (b) final assembly of the vehicle or equipment described in this paragraph has taken place in the United States
 - (4) That inclusion of domestic material will increase the cost of the overall project Contract by more than 25%

 - B. For purposes of this section, in calculating components' costs, labor costs involved in final assembly shall not be included in the calculation.

 - C. Likewise, the Contractor agrees as a condition of responsiveness to and in order to induce the acceptance of this Bid Proposal, that it will submit with its Bid Proposal, a completed Buy America Certification as set forth herein.

3. **Charter Service Operations:** The Charter Bus requirements apply to the following type of Contract: Operational Service Contracts greater than \$3,000. The Contractor agrees to comply with 49 U.S.C. 5323(d) and 49 CFR Part 604, which provides that recipients and sub-recipients of FTA assistance are prohibited from providing charter service using federally funded equipment or facilities if there is at least one private charter operator willing and able to provide the service, except under one of the exceptions at 49 CFR 604.9. Any charter service provided under one of the exceptions must be "incidental," i.e., it must not interfere with or detract from the provision of mass transportation.

4. **School Bus Operations**: The School Bus requirements apply to the following type of Contract: Operational Service Contracts greater than \$3,000. Pursuant to 69 U.S.C. 5323(f) and 49 CFR Part 605, recipients and sub-recipients of FTA assistance may not engage in school bus operations exclusively for the transportation of students and school personnel in competition with private school bus operators unless qualified under specified exemptions. When operating exclusive school bus service under an allowable exemption, recipients and sub-recipients may not use federally funded equipment, vehicles, or facilities.

5. **Cargo Preference – Use of United States Flag Vessels**: The Cargo Preference requirements apply to all Contracts greater than \$3,000 which involving equipment, materials, or commodities which may be transported by ocean vessels. The Contractor agrees:
 - A. To utilize privately owned United States flag commercial vessels to ship at least 50% of the gross tonnage (computed separately for dry bulk carriers, dry cargo lines, and tankers) involved, whenever shipping any equipment, materials, or commodities pursuant to this Contract, to the extent such vessels are available at fair and reasonable rates for United States flag commercial vessels.

 - B. To furnish within 20 days following the date of loading, for shipment originating within the United States or within 30 working days following the date of loading for shipments originating outside the United States, a legible copy of a rated, "on board" commercial ocean bill-of-lading in English for each shipment of cargo described in the preceding paragraph to Pace (through the prime Contractor in the case of subcontractor bills-of-lading) and to the Division of National Cargo, Office of Market Development, Maritime Administration 400 Seventh Street, S.W., Washington, D.C. 20590, marked with appropriate identification of the project.

 - C. To insert the substance of the provisions of this clause in all subcontracts issued pursuant to this Contract.

6. **Seismic Safety**: The Seismic Safety requirements apply only to Contracts for the construction of new buildings or additions to existing buildings which are greater than \$3,000.00. The Contractor agrees that any new building or addition to an existing building will be designed and constructed in accordance with the standards for Seismic Safety required in Department of Transportation Seismic Safety Regulations 49 CFR Part 41 and will certify to compliance to the extent required by the regulation. The Contractor also agrees to ensure that all work performed under this Contract including work performed by a subcontractor is in compliance with the standards required by the Seismic Safety Regulations and the certification of compliance issued on the project.

7. **Energy Conservation Requirements**: The Energy Conservation requirements are applicable to all Contracts which are greater than \$3,000. The Contractor agrees to comply with mandatory standards and policies relating to energy efficiency which are contained in the state energy conservation plan issued in compliance with the Energy Policy and Conservation Act.

8. **Clean Water Requirements**: The Clean Water requirements apply to each Contract and subcontract which exceeds \$100,000. (1) The Contractor agrees to comply with all applicable standards, orders or regulations issued pursuant to the Federal Water Pollution Control Act, as amended, 33 U.S.C. 1251 et seq. The Contractor agrees to report each violation to Pace and understands and agrees that Pace will, in turn, report each violation as required to assure notification to FTA and the appropriate EPA Regional Office. (2) The Contractor also agrees to include these requirements in each subcontract exceeding \$100,000 financed in whole or in part with Federal assistance provided by FTA.

9. **Byrd Anti Lobbying Amendment**: Byrd Anti-Lobbying Amendment, 31 U.S.C. 1352, as amended by the Lobbying Disclosure Act of 1995, P.L. 104-65 [to be codified at 2 U.S.C. § 1601, et seq.] - Contractors who apply or bid for an award of \$100,000 or more shall file the certification required by 49 CFR part 20, "New Restrictions on Lobbying." Each tier certifies to the tier above that it will not and has not used Federal appropriated funds to pay any person or organization for influencing or attempting to influence an officer or employee of any agency, a member of Congress, officer or employee of Congress, or an employee of a member of Congress in connection with obtaining any Federal Contract, grant or any other award covered by 31 U.S.C. 1352. Each tier shall also disclose the name of any registrant under the Lobbying Disclosure Act of 1995 who has made lobbying contacts on its behalf with non-Federal funds with respect to that Federal Contract, grant or award covered by 31 U.S.C. 1352. Such disclosures are forwarded from tier to tier up to the recipient. If any funds other than Federal appropriated funds have been paid or will be paid to any person for influencing or attempting to influence an officer or employee of any agency, a Member of Congress, an officer or employee of Congress, or an employee of a Member of Congress in connection with this Federal Contract, grant, loan, or cooperative agreement, the undersigned shall complete and submit Standard Form-LLL, "Disclosure Form to Report Lobbying," in accordance with its instructions. The Standard Form-LLL shall be submitted to the Pace Legal Department, Attn: General Counsel who, pursuant to federal regulations, will submit the form(s) to the Federal Transit Administration.

- 10. **Audit:** Applicable to all Contracts greater than \$3,000. The Contractor shall permit the authorized representatives of Pace, IDOT, FTA, RTA and the Comptroller General of the United States to inspect and audit all work, materials, data and records of the Contractor relating to performance under the Contract.
- 11. **Federal Changes:** The Federal Changes requirement applies to all Contracts greater than \$3,000. The Contractor shall at all times comply with all applicable FTA regulations, policies, procedures and directives, including without limitation those listed directly or by reference in the FTA Master Agreement (available from the FTA website) between Pace and FTA, as they may be amended or promulgated from time to time during the term of this Contract. The Contractor's failure to so comply shall constitute a material breach of this Contract.
- 12. **Clean Air Requirements:** The Clean Air requirements apply to all Contracts exceeding \$100,000 including indefinite quantities where the amount is expected to exceed \$100,000 in any year. The Clean Air requirements flow down to all subcontracts which exceed \$100,000. (1) The Contractor agrees to comply with all applicable standards, order or regulations issued pursuant to the Clean Air Act, as amended, 42 U.S.C. § 7401 et seq. The Contractor agrees to report each violation to Pace and understands and agrees that Pace will, in turn, report each violation as required to assure notification to FTA and the appropriate EPA Regional Office. (2) The Contractor also agrees to include these requirements in each subcontract exceeding \$100,000 financed in whole or in part with Federal assistance provided by FTA.
- 13. **Recovered Materials:** The Contractor agrees to comply with all the requirements of Section 6002 of the Resource Conservation and Recovery Act (RCRA), as amended (42 U.S.C. 6962), including but not limited to the regulatory provisions of 40 CFR Part 247, and Executive Order 12873, as they apply to the procurement of the items designated in Subpart B of 40 CFR Part 247.
- 14. **Davis-Bacon and Copeland Anti-Kickback Acts:** The Davis-Bacon and Related Acts apply to Contractors and subcontractors performing on federally funded or assisted Contracts in excess of \$2,000 for the construction, alteration, or repair (including painting and decorating) of public buildings or public works.

(1) **Minimum Wages**

- (i) All laborers and mechanics employed or working upon the site of the work (or under the United States Housing Act of 1937 or under the Housing Act of 1949 in the construction or development of the project), will be paid unconditionally and not less often than once a week, and without subsequent deduction or rebate on any account (except such payroll deductions as are permitted by regulations issued by the Secretary of Labor under the Copeland Act (29 CFR part 3)), the full amount of wages and bona fide fringe benefits (or cash equivalents thereof) due at time of payment computed at rates not less than those contained in the wage determination of the Secretary of Labor which is attached hereto and made a part hereof, regardless of any contractual relationship which may be alleged to exist between the Contractor and such laborers and mechanics.

Contributions made or costs reasonably anticipated for bona fide fringe benefits under section 1(b)(2) of the Davis-Bacon Act on behalf of laborers or mechanics are considered wages paid to such laborers or mechanics, subject to the provisions of paragraph (1)(iv) of this section; also, regular contributions made or costs incurred for more than a weekly period (but not less often than quarterly) under plans, funds, or programs which cover the particular weekly period, are deemed to be constructively made or incurred during such weekly period. Such laborers and mechanics shall be paid the appropriate wage rate and fringe benefits on the wage determination for the classification of work actually performed, without regard to skill, except as provided in 29 CFR Part 5.5(a)(4). Laborers or mechanics performing work in more than one classification may be compensated at the rate specified for each classification for the time actually worked therein: Provided, that the employer's payroll records accurately set forth the time spent in each classification in which work is performed. The wage determination (including any additional classifications and wage rates conformed under paragraph (1)(ii) of this section) and the Davis-Bacon poster (WH-1321) shall be posted at all times by the Contractor and its subcontractors at the site of the work in a prominent and accessible place where it can be easily seen by the workers.

- (ii)(A) The contracting officer shall require that any class of laborers or mechanics, including helpers, which is not listed in the wage determination and which is to be employed under the Contract shall be classified in conformance with the wage determination. The contracting officer shall approve an additional classification and wage rate and fringe benefits therefore only when the following criteria have been met:

- (1) Except with respect to helpers as defined as 29 CFR 5.2(n)(4), the work to be performed by the classification requested is not performed by a classification in the wage determination; and
- (2) The classification is utilized in the area by the construction industry; and
- (3) The proposed wage rate, including any bona fide fringe benefits, bears a reasonable relationship to the wage rates contained in the wage determination; and

- (4) With respect to helpers as defined in 29 CFR 5.2(n)(4), such a classification prevails in the area in which the work is performed.

- (B) If the Contractor and the laborers and mechanics to be employed in the classification (if known), or their representatives, and the contracting officer agree on the classification and wage rate (including the amount designated for fringe benefits where appropriate), a report of the action taken shall be sent by the contracting officer to the Administrator of the Wage and Hour Division, Employment Standards Administration, U.S. Department of Labor, Washington, DC 20210. The Administrator, or an authorized representative, will approve, modify, or disapprove every additional classification action within 30 days of receipt and so advise the contracting officer or will notify the contracting officer within the 30-day period that additional time is necessary.

- (C) In the event the Contractor, the laborers or mechanics to be employed in the classification or their representatives, and the contracting officer do not agree on the proposed classification and wage rate (including the amount designated for fringe benefits, where appropriate), the contracting officer shall refer the questions, including the views of all interested parties and the recommendation of the contracting officer, to the Administrator for determination. The Administrator, or an authorized representative, will issue a determination within 30 days of receipt and so advise the contracting officer or will notify the contracting officer within the 30-day period that additional time is necessary.

- (D) The wage rate (including fringe benefits where appropriate) determined pursuant to paragraphs (a)(1)(ii) (B) or (C) of this section, shall be paid to all workers performing work in the classification under this Contract from the first day on which work is performed in the classification.

- (iii) Whenever the minimum wage rate prescribed in the Contract for a class of laborers or mechanics includes a fringe benefit which is not expressed as an hourly rate, the Contractor shall either pay the benefit as stated in the wage determination or shall pay another bona fide fringe benefit or an hourly cash equivalent thereof.

- (iv) If the Contractor does not make payments to a trustee or other third person, the Contractor may consider as part of the wages of any laborer or mechanic the amount of any costs reasonably anticipated in providing bona fide fringe benefits under a plan or program, Provided, That the Secretary of Labor has found, upon the written request of the Contractor, that the applicable standards of the Davis-Bacon Act have been met. The Secretary of Labor may require the Contractor to set aside in a separate account assets for the meeting of obligations under the plan or program.

- (v)(A) The contracting officer shall require that any class of laborers or mechanics which is not listed in the wage determination and which is to be employed under the Contract shall be classified in conformance with the wage determination. The contracting officer shall approve an additional classification and wage rate and fringe benefits therefore only when the following criteria have been met:
 - (1) The work to be performed by the classification requested is not performed by a classification in the wage determination; and
 - (2) The classification is utilized in the area by the construction industry; and
 - (3) The proposed wage rate, including any bona fide fringe benefits, bears a reasonable relationship to the wage rates contained in the wage determination.

- (B) If the Contractor and the laborers and mechanics to be employed in the classification (if known), or their representatives, and the contracting officer agree on the classification and wage rate (including the amount designated for fringe benefits where appropriate), a report of the action taken shall be sent by the contracting officer to the Administrator of the Wage and Hour Division, Employment Standards Administration, Washington, DC 20210. The Administrator, or an authorized representative, will approve, modify, or disapprove every additional classification action within 30 days of receipt and so advise the contracting officer or will notify the contracting officer within the 30-day period that additional time is necessary.

- (C) In the event the Contractor, the laborers or mechanics to be employed in the classification or their representatives, and the contracting officer do not agree on the proposed classification and wage rate (including the amount designated for fringe benefits, where appropriate), the contracting officer shall refer the questions, including the views of all interested parties and the recommendation of the contracting officer, to the Administrator for determination. The Administrator, or an authorized representative, will issue a determination with 30 days of receipt and so advise the contracting officer or will notify the contracting officer within the 30-day period that additional time is necessary.

(D) The wage rate (including fringe benefits where appropriate) determined pursuant to paragraphs (a)(1)(v) (B) or (C) of this section, shall be paid to all workers performing work in the classification under this Contract from the first day on which work is performed in the classification.

(2) **Withholding** – The Suburban Bus Division of the Regional Transportation Authority (Pace) shall upon its own action or upon written request of an authorized representative of the Department of Labor withhold or cause to be withheld from the Contractor under this Contract or any other Federal Contract with the same prime Contractor, or any other federally-assisted Contract subject to Davis-Bacon prevailing wage requirements, which is held by the same prime Contractor, so much of the accrued payments or advances as may be considered necessary to pay laborers and mechanics, including apprentices, trainees, and helpers, employed by the Contractor or any subcontractor the full amount of wages required by the Contract. In the event of failure to pay any laborer or mechanic, including any apprentice, trainee, or helper, employed or working on the site of the work (or under the United States Housing Act of 1937 or under the Housing Act of 1949 in the construction or development of the project), all or part of the wages required by the Contract, the Suburban Bus Division of the Regional Transportation Authority (Pace) may, after written notice to the Contractor, sponsor, applicant, or owner, take such action as may be necessary to cause the suspension of any further payment, advance, or guarantee of funds until such violations have ceased.

(3) **Payrolls and basic records**

(i) Payrolls and basic records relating thereto shall be maintained by the Contractor during the course of the work and preserved for a period of three years thereafter for all laborers and mechanics working at the site of the work (or under the United States Housing Act of 1937, or under the Housing Act of 1949, in the construction or development of the project). Such records shall contain the name, address, and social security number of each such worker, his or her correct classification, hourly rates of wages paid (including rates of contributions or costs anticipated for bona fide fringe benefits or cash equivalents thereof of the types described in section 1(b)(2)(B) of the Davis-Bacon Act), daily and weekly number of hours worked, deductions made and actual wages paid. Whenever the Secretary of Labor has found under 29 CFR 5.5(a)(1)(iv) that the wages of any laborer or mechanic include the amount of any costs reasonably anticipated in providing benefits under a plan or program described in section 1(b)(2)(B) of the Davis-Bacon Act, the Contractor shall maintain records which show that the commitment to provide such benefits is enforceable, that the plan or program is financially responsible, and that the plan or program has been communicated in writing to the laborers or mechanics affected, and records which show the costs anticipated or the actual cost incurred in providing such benefits. Contractors employing apprentices or trainees under approved programs shall maintain written evidence of the registration of apprenticeship programs and certification of trainee programs, the registration of the apprentices and trainees, and the ratios and wage rates prescribed in the applicable programs.

(ii)(A) The Contractor shall submit weekly for each week in which any Contract work is performed a copy of all payrolls to the Suburban Bus Division of the Regional Transportation Authority (Pace) for transmission to the Federal Transit Administration. The payrolls submitted shall set out accurately and completely all of the information required to be maintained under section 5.5(a)(3)(i) of Regulations, 29 CFR part 5. This information may be submitted in any form desired. Optional Form WH-347 is available for this purpose and may be purchased from the Superintendent of Documents (Federal Stock Number 029-005-00014-1), U.S. Government Printing Office, Washington DC 20402. The prime Contractor is responsible for the submission of copies of payrolls by all subcontractors.

(B) Each payroll submitted shall be accompanied by a "Statement of Compliance," signed by the Contractor or subcontractor or his or her agent who pays or supervises the payment of the persons employed under the Contract and shall certify the following:

- (1) That the payroll for the payroll period contains the information required to be maintained under section 5.5(a)(3)(i) of Regulations, 29 CFR part 5 and that such information is correct and complete;
- (2) That each laborer or mechanic (including each helper, apprentice, and trainee) employed on the Contract during the payroll period has been paid the full weekly wages earned, without rebate, either directly or indirectly, and that no deductions have been made either directly or indirectly from the full wages earned, other than permissible deductions as set forth in Regulations, 29 CFR part 3;
- (3) That each laborer or mechanic has been paid not less than the applicable wage rates and fringe benefits or cash equivalents for the classification of work performed, as specified in the applicable wage determination incorporated into the Contract.

(C) The weekly submission of a properly executed certification set forth on the reverse side of Optional Form WH-347 shall satisfy the requirement for submission of the "Statement of Compliance" required by paragraph (a)(3)(ii)(B) of this section.

(D) The falsification of any of the above certifications may subject the Contractor or subcontractor to civil or criminal prosecution under section 1001 of title 18 and section 231 of title 31 of the United States Code.

(iii) The Contractor or subcontractor shall make the records required under paragraph (a)(3)(i) of this section available for inspection, copying, or transcription by authorized representatives of the Federal Transit Administration or the Department of Labor, and shall permit such representatives to interview employees during working hours on the job. If the Contractor or subcontractor fails to submit the required records or to make them available, the Federal agency may, after written notice to the Contractor, sponsor, applicant, or owner, take such action as may be necessary to cause the suspension of any further payment, advance, or guarantee of funds. Furthermore, failure to submit the required records upon request or to make such records available may be grounds for debarment action pursuant to 29 CFR 5.12.

(4) Apprentices and trainees

(i) Apprentices – Apprentices will be permitted to work at less than the predetermined rate for the work they performed when they are employed pursuant to and individually registered in a bona fide apprenticeship program registered with the U.S. Department of Labor, Employment and Training Administration, Bureau of Apprenticeship and Training, or with a State Apprenticeship Agency recognized by the Bureau, or if a person is employed in his or her first 90 days of probationary employment as an apprentice in such an apprenticeship program, who is not individually registered in the program, but who has been certified by the Bureau of Apprenticeship and Training or a State Apprenticeship Agency (where appropriate) to be eligible for probationary employment as an apprentice. The allowable ratio of apprentices to journeymen on the job site in any craft classification shall not be greater than the ratio permitted to the Contractor as to the entire work force under the registered program. Any worker listed on a payroll at an apprentice wage rate, who is not registered or otherwise employed as stated above, shall be paid not less than the applicable wage rate on the wage determination for the classification of work actually performed. In addition, any apprentice performing work on the job site in excess of the ratio permitted under the registered program shall be paid not less than the applicable wage rate on the wage determination for the work actually performed. Where a Contractor is performing construction on a project in a locality other than that in which its program is registered, the ratios and wage rates (expressed in percentages of the journeyman's hourly rate) specified in the Contractor's or subcontractor's registered program shall be observed. Every apprentice must be paid at not less than the rate specified in the registered program for the apprentice's level of progress, expressed as a percentage of the journeymen hourly rate specified in the applicable wage determination. Apprentices shall be paid fringe benefits in accordance with the provisions of the apprenticeship program. If the apprenticeship program does not specify fringe benefits, apprentices must be paid the full amount of fringe benefits listed on the wage determination for the applicable classification. If the Administrator of the Wage and Hour Division of the U.S. Department of Labor determines that a different practice prevails for the applicable apprentice classification, fringes shall be paid in accordance with that determination. In the event the Bureau of Apprenticeship and Training, or a State Apprenticeship Agency recognized by the Bureau, withdraws approval of an apprenticeship program, the Contractor will no longer be permitted to utilize apprentices at less than the applicable predetermined rate for the work performed until an acceptable program is approved.

(ii) Trainees – Except as provided in 29 CFR 5.16, trainees will not be permitted to work at less than the predetermined rate for the work performed unless they are employed pursuant to and individually registered in a program which has received prior approval, evidenced by formal certification by the U.S. Department of Labor, Employment and Training Administration. The ratio of trainees to journeymen on the job site shall not be greater than permitted under the plan approved by the Employment and Training Administration. Every trainee must be paid at not less than the rate specified in the approved program for the trainee's level of progress, expressed as a percentage of the journeyman hourly rate specified in the applicable wage determination. Trainees shall be paid fringe benefits in accordance with the provisions of the trainee program. If the trainee program does not mention fringe benefits, trainees shall be paid the full amount of fringe benefits listed on the wage determination unless the Administrator of the Wage and Hour Division determines that there is an apprenticeship program associated with the corresponding journeyman wage rate on the wage determination which provides for less than full fringe benefits for apprentices. Any employee listed on the payroll at a trainee rate who is not registered and participating in a training plan approved by the Employment and Training Administration shall be paid not less than the applicable wage rate on the wage determination for the classification of work actually performed. In addition, any trainee performing work on the job site in excess of the ratio permitted under the registered program shall be paid not less than the applicable wage rate on the wage determination for the work actually performed. In the event the Employment and Training Administration withdraws approval of a training program, the Contractor will no longer be permitted to utilize trainees at less than the applicable predetermined rate for the work performed until an acceptable program is approved.

(iii) Equal employment opportunity – The utilization of apprentices, trainees and journeymen under this part shall be in conformity with the equal employment opportunity requirements of Executive Order 11246, as amended, and 29 CFR part 30.

(5) Compliance with Copeland Act requirements – The Contractor shall comply with the requirements of 29 CFR Part 3, which are incorporated by reference in this Contract.

- (6) **Subcontracts** – The Contractor or subcontractor shall insert in any subcontracts the clauses contained in 29 CFR 5.5(a)(1) through (10) and such other clauses as the Federal Transit Administration may by appropriate instructions require, and also a clause requiring the subcontractors to include these clauses in any lower tier subcontracts. The prime Contractor shall be responsible for the compliance by any subcontractor or lower tier subcontractor with all the Contract clauses in 29 CFR 5.5.
- (7) **Contract termination: debarment** - A breach of the Contract clauses in 29 CFR 5.5 may be grounds for termination of the Contract, and for debarment as a Contractor and a subcontractor as provided in 29 CFR 5.12.
- (8) **Compliance with Davis-Bacon and Related Act requirements** – All rulings and interpretations of the Davis-Bacon and Related Acts contained in 29 CFR parts 1, 3, and 5 are herein incorporated by reference in this Contract.
- (9) **Disputes concerning labor standards** – Disputes arising out of the labor standards provisions of this Contract shall not be subject to the general disputes clause of this Contract. Such disputes shall be resolved in accordance with the procedures of the Department of Labor set forth in 29 CFR parts 5, 6, and 7. Disputes within the meaning of this clause include disputes between the Contractor (or any of its subcontractors) and the contracting agency, the U.S. Department of Labor, or the employees or their representatives.
- (10) **Certification of eligibility** –
 - (i) By entering into this Contract, the Contractor certifies that neither it (nor he or she) nor any person or firm who has an interest in the Contractor's firm is a person or firm ineligible to be awarded Government Contracts by virtue of section 3(a) of the Davis-Bacon Act or 29 CFR 5.12(a)(1).
 - (ii) No part of this Contract shall be subcontracted to any person or firm ineligible for award of a Government Contract by virtue of section 3(a) of the Davis-Bacon Act or 29 CFR 5.12(a)(1).
 - (iii) The penalty for making false statements is prescribed in the U.S. Criminal Code, 18 U.S.C. 1001

15. **Contract Work Hours and Safety Standards:** This Act applies to construction Contracts greater than \$100,000 and, in very limited circumstances, non-construction projects greater than \$100,000.00 that employ laborers or mechanics on public work.

- (1) **Overtime requirements** – No Contractor or subcontractor Contracting for any part of the Contract work which may require or involve the employment of laborers or mechanics shall require or permit any such laborer or mechanic in any workweek in which he or she is employed on such work to work in excess of forty hours in such workweek unless such laborer or mechanic receives compensation at a rate not less than one and one-half times the basic rate of pay for all hours worked in excess of forty hours in such workweek.
- (2) **Violation; liability for unpaid wages; liquidated damages** – In the event of any violation of the clause set forth in paragraph (1) of this section the Contractor and any subcontractor responsible therefore shall be liable for the unpaid wages. In addition, such Contractor and subcontractor shall be liable to the United States for liquidated damages. Such liquidated damages shall be computed with respect to each individual laborer or mechanic, including watchmen and guards, employed in violation of the clause set forth in paragraph (1) of this section, in the sum of \$10 for each calendar day on which such individual was required or permitted to work in excess of the standard workweek of forty hours without payment of the overtime wages required by the clause set forth in paragraph (1) of this section.
- (3) **Withholding for unpaid wages and liquidated damages** – Pace shall upon its own action or upon written request of an authorized representative of the Department of Labor withhold or cause to be withheld, from any moneys payable on account of work performed by the Contractor or subcontractor under any such Contract or any other Federal Contract with the same prime Contractor, or any other federally-assisted Contract subject to the Contract Work Hours and Safety Standards Act, which is held by the same prime Contractor, such sums as may be determined to be necessary to satisfy any liabilities of such Contractor or subcontractor for unpaid wages and liquidated damages as provided in the clause set forth in paragraph (2) of this section.
- (4) **Subcontracts** – The Contractor or subcontractor shall insert in any subcontracts the clauses set forth in paragraphs (1) through (4) of this section and also a clause requiring the subcontractors to include these clauses in any lower tier subcontracts. The prime Contractor shall be responsible for compliance by any subcontractor or lower tier subcontractor with the clauses set forth in paragraphs (1) through (4) of this section.

16. **No Obligation by the Federal Government:** Applicable to all Contracts greater than \$3,000. (1) Pace and the Contractor acknowledge and agree that, notwithstanding any concurrence by the Federal Government in or approval of the solicitation or award of the underlying Contract, absent the express written consent by the Federal Government, the Federal Government is not a party to this Contract and shall not be subject to any obligations or liabilities to the Pace, the Contractor, or any other party (whether or not a party

to that Contract) pertaining to any matter resulting from the underlying Contract. (2) The Contractor agrees to include the above clause in each subcontract financed in whole or in part with Federal assistance provided by FTA. It is further agreed that the clause shall not be modified, except to identify the subcontractor who will be subject to its provisions.

17. **Program Fraud and False or Fraudulent Statements or Related Acts:** These requirements are applicable to all Contracts greater than \$3,000.

- (1) The Contractor acknowledges that the provisions of the Program Fraud Civil Remedies Act of 1986, as amended, 31 U.S.C. § § 3801 et seq. and U.S. DOT regulations, "Program Fraud Civil Remedies," 49 C.F.R. Part 31, apply to its actions pertaining to this Project. Upon execution of the underlying Contract, the Contractor certifies or affirms the truthfulness and accuracy of any statement it has made, it makes, it may make, or causes to be made, pertaining to the underlying Contract or the FTA assisted project for which this Contract work is being performed. In addition to other penalties that may be applicable, the Contractor further acknowledges that if it makes, or causes to be made, a false, fictitious, or fraudulent claim, statement, submission, or certification, the Federal Government reserves the right to impose the penalties of the Program Fraud Civil Remedies Act of 1986 on the Contractor to the extent the Federal Government deems appropriate.
- (2) The Contractor also acknowledges that if it makes, or causes to be made, a false, fictitious, or fraudulent claim, statement, submission, or certification to the Federal Government under a Contract connected with a project that is financed in whole or in part with Federal assistance originally awarded by FTA under the authority of 49 U.S.C. § 5307, the Government reserves the right to impose the penalties of 18 U.S.C. § 1001 and 49 U.S.C. § 5307(n)(1) on the Contractor, to the extent the Federal Government deems appropriate.
- (3) The Contractor agrees to include the above two clauses in each subcontract financed in whole or in part with Federal assistance provided by FTA. It is further agreed that the clauses shall not be modified, except to identify the subcontractor who will be subject to the provisions.

18. **Ineligible Contractors and Subcontractors:** Applicable to all Contracts of any value. Any name appearing upon the Comptroller General of the United States' list of ineligible Contractors for federally financed and assisted projects shall not be eligible to act as a subcontractor for the Contractor pursuant to this Contract. In the event the Contractor is on the Comptroller General's list of ineligible Contractors for federally financed or assisted projects, this Contract may be canceled, terminated or suspended by Pace.

19. **Contracts Involving Federal Privacy Act Requirements:** When a grantee maintains files on drug and alcohol enforcement activities for FTA, and those files are organized so that information could be retrieved by personal identifier, the Privacy Act requirements apply to all Contracts greater than \$3,000. The following requirements apply to the Contractor and its employees that administer any system of records on behalf of the Federal Government under any Contract: (1) The Contractor agrees to comply with, and assures the compliance of its employees with, the information restrictions and other applicable requirements of the Privacy Act of 1974, 5 U.S.C. § 552a. Among other things, the Contractor agrees to obtain the express consent of the Federal Government before the Contractor or its employees operate a system of records on behalf of the Federal Government. The Contractor understands that the requirements of the Privacy Act, including the civil and criminal penalties for violation of that Act, apply to those individuals involved, and that failure to comply with the terms of the Privacy Act may result in termination of the underlying Contract. (2) The Contractor also agrees to include these requirements in each subcontract to administer any system of records on behalf of the Federal Government financed in whole or in part with Federal assistance provided by FTA.

20. **Civil Rights:** Applicable to all Contracts greater than \$3,000. The Contractor, for itself, its assignees and successors in interests, agrees that it will comply with the following regulations:

- 1) **Construction Contracts** – For any Contract for construction, the Contractor shall comply with the equal opportunity requirements of 41 CFR, Subsection 60-1.4(b)(1) and Subsection 60-1.4(c); the provisions of Executive Order 11246 Subsection 202 and as set forth in the most current FTA Master Agreement available from the FTA website. The Contractor shall include a citation to said requirements in all subcontracts.
- 2) **Nondiscrimination** – In accordance with Title VI of the Civil Rights Act, as amended, 42 U.S.C. § 2000d, section 303 of the Age Discrimination Act of 1975, as amended, 42 U.S.C. § 6102, section 202 of the Americans with Disabilities Act of 1990, 42 U.S.C. § 12132, and Federal transit law at 49 U.S.C. § 5332, the Contractor agrees that it will not discriminate against any employee or applicant for employment because of race, color, creed, national origin, sex, age, or disability. In addition, the Contractor agrees to comply with applicable Federal implementing regulations and other implementing requirements FTA may issue.
- 3) **Equal Employment Opportunity** – The following equal employment opportunity requirements apply to the underlying Contract:

- (a) Race, Color, Creed, National Origin, Sex – In accordance with Title VII of the Civil Rights Act, as amended, 42 U.S.C. § 2000e, and Federal transit laws at 49 U.S.C. § 5332, the Contractor agrees to comply with all applicable equal employment opportunity requirements of U.S. Department of Labor (U.S. DOL) regulations, "Office of Federal Contract Compliance Programs, Equal Employment Opportunity, Department of Labor," 41 C.F.R. Parts 60 *et seq.*, (which implement Executive Order No. 11246, "Equal Employment Opportunity," as amended by Executive Order No. 11375, "Amending Executive Order 11246 Relating to Equal Employment Opportunity," 42 U.S.C. § 2000e note), and with any applicable Federal statutes, executive orders, regulations, and Federal policies that may in the future affect construction activities undertaken in the course of the Project. The Contractor agrees to take affirmative action to ensure that applicants are employed, and that employees are treated during employment, without regard to their race, color, creed, national origin, sex, or age. Such action shall include, but not be limited to, the following: employment, upgrading, demotion or transfer, recruitment or recruitment advertising, layoff or termination; rates of pay or other forms of compensation; and selection for training, including apprenticeship. In addition, the Contractor agrees to comply with any implementing requirements FTA may issue.
 - (b) Age – In accordance with section 4 of the Age Discrimination in Employment Act of 1967, as amended, 29 U.S.C. § § 623 and Federal transit law at 49 U.S.C. § 5332, the Contractor agrees to refrain from discrimination against present and prospective employees for reason of age. In addition, the Contractor agrees to comply with any implementing requirements FTA may issue.
 - (c) Disabilities – In accordance with section 102 of the Americans with Disabilities Act, as amended, 42 U.S.C. § 12112, the Contractor agrees that it will comply with the requirements of U.S. Equal Employment Opportunity Commission, "Regulations to Implement the Equal Employment Provisions of the Americans with Disabilities Act," 29 C.F.R. Part 1630, pertaining to employment of persons with disabilities. In addition, the Contractor agrees to comply with any implementing requirements FTA may issue.
- 4) The Contractor also agrees to include these requirements in each subcontract financed in whole or in part with Federal assistance provided by FTA, modified only if necessary to identify the affected parties.
21. **Patent Rights:** Patent and rights in data requirements for federally assisted projects ONLY apply to research projects in which FTA finances the purpose of the grant is to finance the development of a product or information on Contracts greater than \$3,000. These patent and data rights requirements do not apply to capital projects or operating projects, even though a small portion of the sales price may cover the cost of product development or writing the user's manual. This Agreement shall be subject to the FTA's policy on any invention, improvement, or discovery conceived or first actually reduced to practice in conjunction with planning, research development or demonstration projects as stated in the most current FTA Master Agreement available from the FTA website.
22. **Copyright and Rights in Data:** Patent and rights in data requirements for federally assisted projects ONLY apply to research projects in which FTA finances the purpose of the grant is to finance the development of a product or information on Contracts greater than \$3,000. These patent and data rights requirements do not apply to capital projects or operating projects, even though a small portion of the sales price may cover the cost of product development or writing the user's manual. This Agreement shall be subject to the FTA's policy on copyrights and rights in data with respect to reports and other technical materials developed with in conjunction with planning, research development or demonstration projects. That policy as set forth in the most current FTA Master Agreement available from the FTA website permits the author or grantee to copyright the work but FTA reserves a royalty-free nonexclusive and irrevocable license to reproduce, publish or otherwise use, and to authorize others to use, the work for Government purposes.
23. **Transit Employee Protective Provisions:** The Transit Employee Protective Provisions apply to each Contract greater than \$3,000 for transit operations performed by employees of a Contractor recognized by FTA to be a transit operator.
- (1) The Contractor agrees to comply with applicable transit employee protective requirements as follows:
 - (a) General Transit Employee Protective Requirements – To the extent that FTA determines that transit operations are involved, the Contractor agrees to carry out the transit operations work on the underlying Contract in compliance with terms and conditions determined by the U.S. Secretary of Labor to be fair and equitable to protect the interests of employees employed under this Contract and to meet the employee protective requirements of 49 U.S.C. A 5333(b), and U.S. DOL guidelines at 29 C.F.R. Part 215, and any amendments thereto. These terms and conditions are identified in the letter of certification from the U.S. DOL to FTA applicable to the FTA Recipient's project from which Federal assistance is provided to support work on the underlying Contract. The Contractor agrees to carry out that work in compliance with the conditions stated in that U.S. DOL letter. The requirements of this subsection (1), however, do not apply to any Contract financed with Federal assistance provided by FTA either for projects for elderly individuals and individuals with disabilities authorized by 49 U.S.C. § 5310(a)(2), or for projects for non-urbanized areas authorized by 49 U.S.C. § 5311. Alternate provisions for those projects are set forth in subsections (b) and (c) of this clause.

- (b) Transit Employee Protective Requirements for Projects Authorized by 49 U.S.C. § 5310(a)(2) for Elderly Individuals and Individuals with Disabilities – If the Contract involves transit operations financed in whole or in part with Federal assistance authorized by 49 U.S.C. § 5310(a)(2), and if the U.S. Secretary of Transportation has determined or determines in the future that the employee protective requirements of 49 U.S.C. § 5333(b) are necessary or appropriate for the state and the public body sub-recipient for which work is performed on the underlying Contract, the Contractor agrees to carry out the Project in compliance with the terms and conditions determined by the U.S. Secretary of Labor to meet the requirements of 49 U.S.C. § 5333(b), U.S. DOL guidelines at 29 C.F.R. Part 215, and any amendments thereto. These terms and conditions are identified in the U.S. DOL's letter of certification to FTA, the date of which is set forth Grant Agreement or Cooperative Agreement with the state. The Contractor agrees to perform transit operations in connection with the underlying Contract in compliance with the conditions stated in that U.S. DOL letter.
- (c) Transit Employee Protective Requirements for Projects Authorized by 49 U.S.C. § 5311 in Non-urbanized Areas – If the Contract involves transit operations financed in whole or in part with Federal assistance authorized by 49 U.S.C. § 5311, the Contractor agrees to comply with the terms and conditions of the Special Warranty for the Non-urbanized Area Program agreed to by the U.S. Secretaries of Transportation and Labor, dated May 31, 1979, and the procedures implemented by U.S. DOL or any revision thereto.

(2) The Contractor also agrees to include any applicable requirements in each subcontract involving transit operations financed in whole or in part with Federal assistance provided by FTA.

- 24. **Drug and Alcohol Testing:** This provision applies to all Operational Service Contracts greater than \$3,000. The Contractor agrees to participate in Pace’s drug and alcohol program established in compliance with 49 CFR 655 which if applicable shall be attached as a separate exhibit to this Contract.
- 25. **Incorporation of Federal Transit Administration (FTA) Terms:** The incorporation of FTA terms applies to all Contracts greater than \$3,000. The preceding provisions include, in part, certain Standard Terms and Conditions required by DOT, whether or not expressly set forth in the preceding Contract provisions. All contractual provisions required by DOT, as set forth in FTA Circular 4220.1F or most recent version are hereby incorporated by reference. Anything to the contrary herein notwithstanding, all FTA mandated terms shall be deemed to control in the event of a conflict with other provisions contained in this Agreement. The Contractor shall not perform any act, fail to perform any act, or refuse to comply with any Suburban Bus Division of the Regional Transportation Authority (Pace) requests which would cause the Suburban Bus Division of the Regional Transportation Authority (Pace) to be in violation of the FTA terms and conditions.
- 26. **Veterans Employment:** Recipients and subrecipients of Federal financial assistance under this chapter shall ensure that contractors working on a capital project funded using such assistance give a hiring preference, to the extent practicable, to veterans (as defined in section 2108 of title 5) who have the requisite skills and abilities to perform the construction work required under the contract. This subsection shall not be understood, construed or enforced in any manner that would require an employer to give preference to any veteran over any equally qualified applicant who is a member of any racial or ethnic minority, female, an individual with a disability, or former employee.

IDOT/RTA/State Requirements

- 27. **Illinois Prevailing Wage Act (820 ILCS 130):** It is the policy of the State of Illinois that a wage of no less than the general prevailing hourly rate as paid for work of a similar character in the locality in which the work is performed, shall be paid to all laborers, workers and mechanics employed by or on behalf of any and all public bodies engaged in public works. This Act applies to the wages of laborers, mechanics and other workers employed in any public works, as stated in the Illinois Prevailing Wage Act (820 ILCS 130), by any public body and to anyone under Contract for public works. This includes any maintenance, repair, assembly, or disassembly work performed on equipment whether owned, leased, or rented. Public works is defined as all fixed construction work performed by or on behalf of any public body, paid in whole or in part with public funds.

Only such laborers, workers and mechanics as are directly employed by contractors or subcontractors in actual construction work on the site of the building or construction job, and laborers, workers and mechanics engaged in the transportation of materials and equipment to or from the site, but not including the transportation by the sellers and suppliers or the manufacturer or processing of materials or equipment, in the execution of any contract or contracts for public works with any public body shall be deemed to be employed upon public works. The wage for a tradesman performing maintenance is equivalent to that of a tradesman engaged in construction or demolition.

- 28. **Bid Evaluation Requirements:** In the event a single bid is received, it may be necessary for Pace to conduct a price and or cost analysis of the bid price with the Contractor's full cooperation. The Contractor shall provide all documents requested by Pace to perform the analysis.

29. **The Americans with Disabilities Act:** Applicable to all Contracts greater than \$3,000. The Contractor agrees to comply with, and assure that any subcontractor complies with all applicable requirements of 42 USC 12101 et seq.
30. **Use of Metric Units of Measure and English Language:** All Contract documents, conferences, letters, technical information and drawings provided by the Contractor shall be conducted or offered solely in the English language and using both the U.S. customary system of weights and measures and the Metric units system of weights and measures.
31. **Interest of Members of Congress:** No member of or delegate to the Congress of the United States shall be admitted to any share or part of this Contract or to any benefit arising therefrom.
32. **Financial Assistance Contract:** This Contract is subject to the provisions of the financial assistance Contracts between Pace and other sponsoring agencies which are identified in the Invitation for Bids as FTA, IDOT, and RTA.
33. **State of Illinois Ineligible Contractors and Subcontractors:** The Contractor shall certify that it is not barred from contracting with any unit of State or local government as a result of a violation of either Section 33E-3 or 33E-4 of the Illinois Criminal Code (Ill. Rev. Stat. Chap.38,33E-1,ET.SEQ.)

**INVITATION FOR BID NO 419131
WIRELESS MOBILE COLUMN LIFTS AND SUPPORT STANDS
SPECIFICATIONS**

1.0 DESCRIPTION

This specification describes new wireless, battery powdered mobile column lifting system with low voltage microprocessor-controlled tracking system hereinafter call "Lift." The Lift shall be designed to safely and reliably raise Pace's transit buses. When delivered, the Lift shall be complete, fully assembled and ready to use.

The Lift and all associated equipment furnished in this specification shall be the most modern design. The material, equipment and workmanship shall be of the highest commercial quality.

1.1 Pace's Purchasing Department or duly authorized representative shall be the final authority for deciding as to whether a competitive item conforms to these requirements and complies with the intention of this specification.

1.2 This specification is intended to be descriptive but not restrictive and is solely for indicating the type and quality of article which will meet the approval of Pace.

2.0 TECHNICAL SPECIFICATIONS

2.1 Lifting Capacity

Each column of the Lift shall have a rated capacity of a minimum of 18,000 lbs. The column shall be protected against overloading.

2.1.1 Lifting System

The Lift shall be re-circulating ball screw or hydraulic with microprocessor-controlled tracking system.

2.1.2 Lifting Height

The lifting height shall be a maximum of 73 inches and the minimum shall be 69 inches with automatic stop in the highest position.

2.1.3 Lifting Time

Total lifting time shall be a maximum of 89 seconds when fully charged and no greater than 70 seconds in descent.

2.1.4 Electrical

Each column of the Lift shall contain its own power supply which consists of two (2) deep cycle 12 VDC batteries combined.

The 24 VDC on board power supply shall incorporate a built in 110V recharging system with indicator lamps. The charger indicator lamp shall illuminate a red lamp when system is recharging, even if the main power switch is in the OFF position. Once the batteries have achieved a full charge, the charge indicator lamp shall illuminate to inform the operator the batteries have been fully charged.

Columns with charging system without indicator lamps shall not be acceptable.

The main power shall be fused between the primary power switch and the motor/control circuits to protect against overload. Columns without input power fusing shall not be acceptable.

When fully charged, the on-board battery power system shall be capable of a minimum of 20 lifting/ lowering cycles at full capacity. Lifts not capable of 20 lifting/lowering cycles at full capacity shall be unacceptable.

2.1.5 Weight

The weight shall be a maximum of 1400 lbs. per column of the Lift. Each column shall be equipped with and analog weight gauge to monitor the load being lifted.

2.1.6 CONTROLS

2.1.7 The various functions of the system shall be initiated from the control panel on the column.

2.1.8 Each Lifts' column control panel shall have a palm activated emergency stop switch which stops all movement, either ascent or descent, within 1/3000th of one second after activation.

2.1.9 Each column of the Lift shall contain identically:

- Control panel with information display
- “Up” button
- “Down” button
- An emergency stop switch
- Printed circuit board
- Motor relays for all input voltage
- Reserve fuse(s) for control system
- Selection button
- A slow lowering
- Main power disconnect

2.1.10 Each control panel shall have an “automatic” height reference setting “function” which allows at start up the setting of the height memory and the operation, on an individual basis, of any individual column.

2.1.11 Control voltage in each control box shall not exceed 24 VDC.

2.1.12 The control system shall be completely wireless requiring no interconnecting cables between the columns. The wireless communication system shall be properly shielded from external interference in the workshop.

2.1.14 Single operation of any column of the Lift in the set shall be possible from that column at any time and at any height.

2.1.15 Paired operation shall be possible with a set consisting of an even number of columns, two, four, six and up to eight columns. Paired operation shall be engaged by activation of the selector button on a column until the paired indicated is illuminated on that particular column. At this time, the operator shall have the option to initiate linking of that column with another column by selecting the paired feature through the selector button on that column. Once this pairing is completed, it will remain possible to lift that pair of columns at any time and at any height until the power is disconnected.

- 2.1.16 Paired or single operations shall be permitted from any height position of the lifting column(s).
- 2.1.17 It shall switch back and forth/to and from individual, paired or synchronous operation (group) in any order regardless of physical location or height setting.
- 2.1.18 The Lift shall include an information display on the outside of the column to facilitate ease of operation.

The information display shall indicate to the operator:

- Actual number of columns in set (set size). This numeric indicator shall immediately inform the operator of the number of columns currently included in the set.
- Actual number of that particular column in the set of columns. Since the columns are addressed by the control system at the time of start-up, this column indicator shall inform the operator of what number a particular column is in a set of columns.
- Actual lifting height: This numeric indicator shall give the operator an immediate reference to determine the achieved height of a particular column.
- Action in process (lifting/lowering). This indicator shall inform the operator of what is taking place.
- Battery condition. This indicator shall provide the operator a quick reference that illustrates the charge condition of the batteries.
- Hours in service of that particular column. This indicator shall inform the operator of the time that a particular column has been in service to ensure proper maintenance is completed in a timely manner.
- Fault codes to facilitate trouble shooting. This group of numeric indicators shall aid the operator in troubleshooting of the column.

This information display shall allow the operator to view through button manipulation.

- Initiation of multilingual operation. The columns shall have the ability to communicate with the operator in English. The language shall be able to be changed by the operator at the time of operation without control system modification. The language change shall remain in place until changed by the operator.
- Initiation of height restricted operation. The columns shall have the ability for the operator to restrict the achieved height of any or all columns in a set. The restricted height setting shall remain in memory until the height restrictions are removed by the operator. Columns that do not retain height restrictions once the main power is disconnected shall not be acceptable.
- Initiation of lifting with the lock released for reduced noise output. The column shall allow the operator to initiate the retraction of the locking pawl during lifting if the operator finds the noise generated by the locking pawl to be undesirable.

- Initiation of crush limitation (block lowering below 12 inches) so that the columns will not lower when a remote controller is installed to prevent injury by lift.

2.1.19 Control system shall utilize a micro-processor integrated within the printed circuit board to provide the various safety and operational requirements described above. The control systems adaptive leveling function shall be provided by an analog measuring device such as a potentiometer. Encoders or other systems that utilize PLC's (programmable logic controllers) shall not be permitted since they do not measure absolute limits.

2.1.20 The control system shall ensure maximum reliability and safety. This shall ensure that the columns desired by the operator are the only columns in communication and under control of the operator.

2.1.21 The entire printed circuit board shall be able to be removed and replaced in less than 5 minutes.

2.1.22 Control panel shall be rated NEMA 4.

2.2 **ASSOCIATED EQUIPMENT**

2.2.1 **SAFETY STANDS**

Support stands capable of safely supporting buses at varying working heights shall be provided. The manufacturer shall clearly label the stands with the rated capacity. The stands shall be rated for and be capable of supporting the bus when the mobile column lifts are lowered and or removed from supporting the bus.

Four (4) axle supports with a capacity of 18 tons each for every 72,000-pound lift. Support stands shall utilize ACME type screw for up to 6 inches of fine height adjustment.

2.2.2 **HIGH LIFT WHEEL DOLLY**

High lift wheel dollies shall be provided with a capacity of 1000 pounds, maximum lifting height 52" with a lift speed of 78" per minute and pneumatic operation.

2.3 **REGULATIONS**

2.3.1 The lift shall comply with Federal, State and local regulations, including the following:

- ANSI/ALI-ALCTV
- OSHA General Industry Safety Orders – ALI/ETL Standards.

The Lifts shall have an ALI/ETL Certification Label or reference the ALI Certification Program regarding the Lift(s).

There shall be no exposed or unguarded rotating gears, shafts or rollers. Safety's shall be in place to deactivate the system to prevent pinching of personnel, cables, tools or other obstructions as lifting carriage descends.

2.3.2 The Contractor certifies that the equipment offered complies with all Federal and State regulations.

3.0 **QUALITY INSURANCE**

The Lift shall be manufactured, assembled and installed to the highest standard of industry.

4.0 **WARRANTY**

The Mobile Column Lift System shall be warranted to be free from defects due to materials and/or workmanship for a minimum period of one (1) year from delivery to and acceptance by Pace. The manufacturer's standard published warranties applicable to the model provided to Pace under this procurement shall be provided.

5.0 **GENERAL REQUIREMENTS**

5.1 **Components**

The Lift shall include all of the manufacturer's standard components without omissions plus additional components as the Specification requires.

5.2 **Capacities and Dimensions**

Capacities and dimensions listed herein shall be construed as minimum.

5.3 **Interchangeability**

All units and components procured under this contract, whether provided by suppliers or manufactured by the Contractor shall be duplicates in design, manufacture and installation to assure interchangeability among the Lift in the procurement. This interchangeability shall extend to the individual components as well as to their locations.

5.4 **Training**

The Contractor shall provide training to Pace staff members for proper use, maintenance and safety of the units provided. This is to include all Pace Maintenance personnel consisting of three (3) shifts at all Pace divisions listed in the delivery of Wireless Mobile Column Lifts and Associated Equipment. Training sessions are to be a minimum of one (1) hour per shift. Training shall be scheduled through the Superintendent of Maintenance for each respective Pace division. Training must be provided after delivery to Pace and before acceptance by Pace.

5.5 **Manuals**

The Contractor shall supply one (1) copy per lift, and supporting stand, of maintenance manuals, parts and operating manuals when the Lifts are delivered. Delivery of the manuals shall be completed before acceptance of the Lifts.

5.6 **Documentation**

The Contractor shall provide descriptive literature on the Lift and all optional equipment. Bids not made so shall be deemed non-responsive.

**INVITATION FOR BID NO. 419131
WIRELESS MOBILE COLUMN LIFTS AND SUPPORT STANDS
DELIVERY LOCATIONS**

The following wireless mobile column lifts, support stands and high lift dollies shall be delivered as follows:

Pace South Division, 2101 West 163rd Street, Markham, IL 60426, Attn: Supt. of Maintenance.

- 7 Vehicle Lifts (set of 4)
- 7 Support Stands (set of 4)
- 2 High Lift Wheel Dolly

Pace South Holland Division, 405 Taft Drive, South Holland IL 60473, Attn: Supt. of Maintenance.

- 1 Vehicle Lifts (set of 4)
- 1 Support Stand (set of 4)

Pace Southwest Division, 9889 S. Industrial Drive, Bridgeview, IL 60455, Attn: Supt. of Maintenance

- 3 Vehicle Lifts (set of 4)
- 3 Support Stands (set of 4)
- 2 High Lift Wheel Dolly

Pace North Division, 1400 West 10th Street, Waukegan, IL 60202 Attn: Supt. of Maintenance.

- 1 Vehicle Lifts (set of 4)
- 1 Support Stand (set of 4)
- 1 High Lift Wheel Dolly

Pace North Shore Division, 2330 Oakton Street, Evanston, IL 60085, Attn: Supt. of Maintenance.

- 1 Vehicle Lifts (set of 4)
- 1 Support Stands (set of 4)
- 1 High Lift Wheel Dolly

Pace Northwest Division, 900 E. Northwest Highway, Des Plaines, IL 60016, Attn: Supt. of Maintenance

- 3 Vehicle Lifts (set of 4)
- 3 Support Stand (set of 4)
- 2 High Lift Wheel Dolly

Pace River Division, 975 S. State Street, Elgin, IL 60123, Attn: Supt. of Maintenance.

- 2 Vehicle Lifts (set of 4)
- 2 Support Stands (set of 4)
- 2 High Lift Wheel Dolly

Pace West Division, 3500 West Lake Street, Melrose Park, IL 60160, Attn: Supt. of Maintenance.

- 6 Vehicle Lifts (set of 4)
- 6 Support Stands (set of 4)
- 2 High Lift Wheel Dolly

Insurance Requirements

The Insurance documentation must be submitted, reviewed and approved by Pace, the Suburban Bus Division of the Regional Transportation Authority (further known as Pace) prior to the Contract award. At Pace's discretion, the bidder or proposer's failure to submit the required compliant insurance documents may result in a "Not Responsible" determination against your company. Pace also reserves the right to accept or reject the evidence of insurance coverage or other documentation provided at its own discretion.

The Contractor, Supplier and/or Vendor (further known as *Contractors*) or Subcontractors and/or Independent Contractors (further known as *Subs/Independents*) shall provide and maintain insurance coverage required by this Contract. Evidence of required insurance coverage shall be provided on an **Acord 25** (or equivalent) Certificate of Insurance form. It is the *Contractors'* responsibility to verify that all *Subs/Independents* insurance coverage meets or exceeds the insurance requirements outlined in this exhibit/contract. All insurers must maintain a rating of **A-VII** or better as rated by A. M. Best Company. If an A.M. Best rating is not available due to insurance coverage being underwritten by an alternative Risk Financing Method (i.e. Self-Insurance, Pooling, Captive) then the *Contractors* and/or insurer(s) shall provide **Pace** with the most recent audited financial statement, audit report notes, and any applicable State Insurance Department self-insurance approval documents.

It is important to note that "Additional Insured" endorsements such as CG 2010 & CG 2037 or CG 2026 or comparable endorsement {General Liability}, CA 2048 {Automobile Liability}, and other policy endorsements (or their equivalents) required by this exhibit shall be submitted to Pace with the Acord 25 Certificate of Insurance before award of contract.

The *Contractors* shall insert the substance of this Insurance Exhibit in subcontracts under this Contract and shall require all *Subs/Independents* to provide and maintain the insurance required. **It is the Contractors' sole responsibility to ensure all Subcontractors/Independent Contractors insurance is in compliance with these requirements.**

Minimum insurance requirements are those paragraphs below marked with an X:

- Certificates of Insurance** shall provide evidence of all required insurance coverage, limits and endorsements and shall be issued to **Pace** for the duration of the contract or agreement term **plus** one additional year. If a *Contractors'* warranty or material warranty applies, evidence of insurance coverage shall be provided to **Pace** for the entire length of *Contractors'* warranty, and/or the length of materials warranty, whichever is greater. The *Contractors'* agent, broker, or insurer shall issue an updated Certificate of Insurance accompanied by required endorsements to **Pace** prior to the insurance policy renewal date each year.
- Workers Compensation and Employer's Liability Insurance** affording the following limits: **Coverage A-** Statutory Benefits and **Coverage B-Employer's Liability**-\$500,000 Each Accident, \$500,000 Disease-Each Employee, \$500,000 Disease-Policy Limit. Executive Officers, Sole Proprietors, General Contractor's utilizing Independent Contractor labor, and/or others not required by the Illinois Workers Compensation Act to obtain Workers Compensation insurance coverage agree to execute a **hold-harmless agreement**.
- Workers Compensation Waiver of Subrogation**
The *Contractors* and its insurer shall agree to waive their rights to subrogate against **Pace** and the Regional Transportation Authority. **Pace** shall be scheduled and/or named on the ISO WC 00 03 13 endorsement or equivalent WC Waiver of Subrogation.
- Commercial General Liability Insurance (Broad Form)** with coverage and limits that meet or exceed the following parameters; coverage is written on an ISO CG 00 01 or other equivalent coverage form with the following limits:
 - Each Occurrence-\$1,000,000
 - General Aggregate-\$2,000,000
 - Products/Completed Operations Aggregate-\$2,000,000
 - Personal & Advertising Injury-\$1,000,000

- With respect to the **Commercial General Liability Insurance**, the **Regional Transportation Authority (RTA)** and **Pace, the Suburban Bus Division of the RTA**, shall be added by endorsement as Additional Insureds on the *Contractor's* CGL policy.
- Business Automobile Insurance** with a Combined Single Limit (CSL) of not less than \$1,000,000 per accident for bodily injury and property damage liability arising from owned, non-owned, and hired vehicles.
- With respect to the **Business Auto Liability Insurance**, the **Regional Transportation Authority (RTA)**, and **Pace, the Suburban Bus Division of the RTA**, shall be added by endorsement as Additional Insureds on the *Contractor's* Auto policy.
- Umbrella Liability Insurance** affording limits of not less than **\$1,000,000** each occurrence and **\$1,000,000** aggregate coverage. Such umbrella coverage shall contain the following policy provisions and/or endorsements: defense, investigation, and supplementary payments "outside" or "in addition to" the policy limits, 30 day Notice of Cancellation, Definition of "Who is an insured" (includes "Any person or organization" that is an insured under any policy of underlying coverage) and the *Contractor* must maintain underlying insurance as scheduled when the Umbrella coverage was bound. **Umbrella Liability Insurance is not required when the Primary General Liability policy limits and the Primary Automobile Liability policy limits are equal to or greater than the combined total of the Primary and Umbrella insurance policy limits requirement.**
- The *Contractors'* **"Other Insurance" policy clause** shall be shown on the Certificate of Insurance with the following wording **"This insurance is primary, non-contributory, and not excess of any other insurance of Pace.**

Notice of Cancellation on all Policies

The Insurer and/or Agent/Broker shall endeavor to provide the written notice of cancellation to **Pace's** Insurance Liaison **30** days prior to the effective date of cancellation. Failure to do so shall impose no obligation or liability of any kind upon the insurer, its agents or representatives.

Disclosure of a Deductible or Self-Insured Retention (SIR)

If your company is self-insured or utilizes a Risk Financing Mechanism in which a deductible or SIR (self-insured retention) exceeds \$25,000, **Pace** reserves the right to request the most recent audited financial statements from the contractor and documents from the State Insurance Department granting self-insurance approval.

Within five (5) business days of Pace's request and prior to contract award the insurance company, or its representative, shall submit an insurance certificate and corresponding endorsements that meet or exceed Pace's requirements.

Pace, the Suburban Bus Division of the Regional Transportation Authority
Attn: Insurance Liaison
550 West Algonquin Road
Arlington Heights, IL 60005-4412

FAILURE to comply with **Pace's** Insurance Requirements and provide evidence of insurance coverage as required by contract may result in your bid or proposal being rejected as not responsible. The *Contractors'* failure to carry, maintain and/or document required insurance shall constitute a breach of the contract. Any failure by **Pace** to demand or receive proof of insurance coverage shall not constitute a waiver of *Contractors'* obligation to obtain the required insurance. The *Contractors'* expressly agree that these insurance provisions in no way limit the *Contractors'* responsibilities under other provisions of the Contract, including the hold harmless and indemnification clause. *Contractors'* insurance agent shall, upon request by **Pace**, furnish a copy of the insurance policy addressed to the Insurance Liaison. *Contractors* shall not commence work herein until they have obtained the required insurance and has received **Pace's** approval.



DIVISION 14 45 00

VEHICLE LIFTS(ST 1085 FWA ebright)

PART 1 GENERAL

1.1 SECTION INCLUDES

- A. Mobile column lifts.

1.2 RELATED SECTIONS

- A. Section 03 30 00 - Concrete: Footings and foundations.
- B. Section 26 05 00 - Common Work Results for Electrical.

1.3 SUBMITTALS

- A. Submit under provisions of Section 01 30 00 - Administrative Requirements.
- B. Product Data: Manufacturer's data sheets on each product to be used, including:
 - 1. Preparation instructions and recommendations.
 - 2. Storage/handling requirements and recommendations.
 - 3. Installation methods.
- C. Shop Drawings: Submit drawings showing full layout of all lifts with dimensions
- D. Operation and Maintenance Manual: Submit Operation and Maintenance manual to include system operation, maintenance and troubleshooting, spare part numbers, drawings and schematics.

1.4 QUALITY ASSURANCE

- A. Manufacturer Qualifications: The lift company selling the product shall have ISO-9001 certification and the proof of current certification shall accompany the bid.
- B. Installer Qualifications: For warranty validation, installation shall be performed by qualified factory authorized and trained personnel.
- C. Product Requirements:
 - 1. Design Standards and Certification: The lift shall be certified by ETL/Intertek to the ANSI/ALI ALCTV-current edition Standard for Automotive Lifts: Safety Requirements for Construction, Testing and Validation.
 - 2. The drive system shall permit lifting without any pulsation, jerks, or unsteady lifting. Lifting shall be smooth. System shall be comprised of an electrically powered pump, flow control valves, and a fluid reservoir. An electronic/hydraulic synchronization system shall ensure smooth alignment of each lifting assembly based on variances in vehicle weight. A microprocessor shall control all lift movement for ultimate operator safety and convenience. Troubleshooting codes shall facilitate service and repair.

1.5 DELIVERY, STORAGE, AND HANDLING

- A. Store products in manufacturer's unopened packaging until ready for installation.
- B. Store and dispose of solvent-based materials, and materials used with solvent-based materials, in accordance with requirements of local authorities having jurisdiction.

1.6 PROJECT CONDITIONS

- A. Maintain environmental conditions (temperature, humidity, and ventilation) within limits recommended by manufacturer for optimum results. Do not install products under environmental conditions outside manufacturer's absolute limits.

1.7 WARRANTY

- A. Manufacturer's Warranty: Lift system shall be warranted for a minimum period of 2 years for parts and 1 year for labor. Hydraulic cylinder shall have a parts only warranty of an additional four years. Guide rollers shall have a lifetime warranty; this extended warranty covers parts only.

PART 2 PRODUCTS

2.1 MANUFACTURERS

- A. Acceptable manufacturer: Stertil-Koni USA, Inc., which is located at: 200 Log Canoe Circle; Stevensville, MD 21666; Toll Free Tel: 800-336-6637; Tel: 410-643-9001; Email: requestinfo@sterdil-koni.com; Web: www.sterdil-koni.com
- B. Requests for substitutions will be considered in accordance with provisions of Section 00 26 00.
 - 1. Requests for changes by the contractor on products, materials, equipment and methods of construction required by the contract documents, after the award, shall be considered requests for "substitutions", and shall follow the procedures outlined within the bid documents for substitutions.
 - 2. Any substitution of the specified lift requiring modifications of foundation system detailed will be the responsibility of the contractor.
 - 3. The contractor shall provide for any and all engineering and redesign of foundation system as a result of substitution.
 - 4. Under no circumstances will extra payment be permitted as a result of additional work to accommodate any equipment substitution.

2.2 MOBILE COLUMN LIFTS

- A. Mobile Column Lifts Model ST-1085-FWA(ebright) as manufactured by Stertil-Koni USA, Inc.
 - 1. General Description:
 - a. A lifting system or set (consisting of up to 32 columns) for vehicles shall be composed of interchangeable columns. The size of the set shall be able to be configured by the operator at time of set up without the need to modify the operating system. It shall be possible to operate up to 480 columns within any facility. With a set of up to 32 columns, it shall be possible to operate any single column, a pair of columns, or all columns together, at the same time.
 - b. Each column shall contain its own power supply which consists of two deep cycle (group 31) 12 VDC batteries combined to provide a stable 24 VDC power supply.

- c. The main power shall be fused between the primary power switch and the motor/control circuits to protect against overload.
 - d. When fully charged, the on board battery power system shall be capable of 19 lifting/lowering cycles at 100% of lifting capacity and 28 lifting/lowering cycles at 50% of lifting capacity .
 - e. The 24 VDC on board power supply shall incorporate a built in recharging systems with a pictograph on the display so the operator can visually verify charging status.
 - 1) The recharging system shall be a built in 110 VAC battery charger with indicator lamps. The battery charger shall be enclosed within a steel cabinet for protection from damage. The charger indicator lamp shall be easily visible through a sight glass mounted externally in the control cabinet. The indicator lamp shall be illuminated steady red when the system is recharging, green when batteries are fully recharged, and flashing green when the charger is providing a trickle charge. It shall be possible to operate the lifting column while the battery charger is actively charging the batteries.
 - f. The base frame of the lifting column shall be of a rectangular design. The contact pattern to the foundation under the column shall be triangular in design to ensure uniform contact with the lifting foundation.
2. Lifting Capacity:
 - a. Each individual column shall have a nominal rated capacity of 18,500 lbs. (8,500 kg).
 3. Dimensions:
 - a. The achieved lifting height of the column shall be no less than 73 inches (1,854 mm) when measured from the foundation on which the column rests to the top of the lifting fork.
 - b. Column height shall not be greater than 97 inches (2,464 mm) when fully lowered and 143.5 inches (3,645 mm) when the carriage has achieved maximum height.
 - c. Column lifting fork shall be 14 inches in length.
 4. Tire Size:
 - a. Wheel contact forks shall be adjustable by hand and freely accept tires with rim diameters between R10 and R22.5. The adjustable forks shall incorporate a mechanical locking device to ensure the fork cannot relocate/adjust during use.
 5. Pallet Jack Mechanism:
 - a. The pallet jack mechanism shall have a gas shock incorporated into its design which shall serve two purposes. The primary purpose of the pallet jack gas shock shall be to serve as a safety mechanism to ensure that the mobile column is not lifting, while the pallet jack is extended. If the operator fails to lower the pallet jack after column positioning, as soon as the column experiences load during a lifting cycle, the gas shock will retract to lower the column to its foundation for stable lifting. The second purpose of the pallet jack gas shock shall be to dampen the impact of floor imperfections experienced while the column is relocated.
 6. Wheels:
 - a. The column shall be fitted with fixed front roller wheels fabricated from oil impregnated nylon so as to be non-destructive to the foundation on which the column rests.
 - b. Floor pressure at the front roller wheel location shall be no greater than 7,200 lbs.
 7. Drive Mechanism:
 - a. The drive system shall be hydraulic and shall permit lifting without any

- pulsation, jerks, or unsteady lifting. Lifting shall be smooth. The hydraulic power unit shall be an electrically-powered pump, flow control valves, and a fluid reservoir.
- b. Lifting carriage shall ride on durable, oil filled nylon guide rollers. Guide rollers shall require no lubrication and no maintenance.
 - c. Each hydraulic cylinder shall be equipped with a hose burst check valve to prevent decent in the event of a major fluid leak.
8. Controls:
- a. The various functions of the mobile lifting system shall be initiated from the control panels on the columns.
 - b. Each control box shall include:
 - 1) "UP" button.
 - 2) "Down" button.
 - 3) "Lock release" button.
 - 4) "Confirm" button
 - 5) Mushroom style emergency stop button
 - 6) A high definition 7 inch LCD screen touch. The touch screen shall be specifically designed for a harsh workshop environment. The touch screen shall be capable of providing the following functions:
 - i. Column selection indicator: This area of the touch screen display shall inform the operator of which columns in the set have been selected for operation.
 - ii. Battery charge indicator: This area of the touch screen display shall inform the operator of the charge condition of the battery power supply.
 - iii. Column height indicator: This area of the touch screen display shall inform the operator of the height of the individual column. The operator shall have the ability to easily toggle between individual imperial or metric units of height measurement (inches or mm.). The column height indicator shall also provide on the touch screen a clear indicator if the column has been set to stop at a restricted lifting height. This indicator shall be displayed as a thick horizontal line in the height display region of the touch screen. As the column rises, the screen will mimic the column and display the lifting fork rising up towards the horizontal restricted height indicator bar. Once the lifting fork shown on the display arrives at the restricted height indicator bar, the column shall stop rising.
 - iv. Column speed indicator: This area of the touch screen shall inform the operator of the speed of the lifting system. The speed indicator shall have the ability to adjust the lowering to 30% of full lowering speed.
 - v. Column fault code indicator: When a fault code has been registered by the control system, the touch screen shall inform the operator of any fault codes affecting the lifting set. The control system shall have the ability to display 42 individual fault codes.
 - vi. One-touch access to the **Guide screen**: This area of the touch screen provides to the operator access to the **Guide screen**. The **Guide screen** shall provide to all system users:
 - i. Calculator
 - vii. One-touch access to the **Information screen**: This area of the touch screen provides to the operator access to:
 - i. Owner information
 - ii. Service provider information

- iii. Manufacturer information
- viii. One-touch access to the **Settings screen** which displays 5 options which allows management of :
 - i. Settings screen option (1): On this screen, operators shall have the ability to change the language displayed on the screen as well as the units of measure for height and weight (imperial or metric units).
 - ii. Settings screen option (2): On this screen, operators shall have the ability to retract the mechanical locks during raising for reduced noise, as well as to set a restricted maximum lifting height.
 - iii. Area to allow for future expansion
 - iv. Portal to the **Shop screen**: access to this screen requires a PIN with details of the Shop Screen provide below.
 - v. Portal to **Information screen** option: access to this screen requires a PIN with details of the Information Screen provide below.
- ix. One-touch access to the **Shop screen** options (access to the **Shop screen** shall be generally provided to only maintainers and system administrators). The shop configuration screen shall allow manipulation of:
 - i. Edit of owner's details: on this screen shall be the ability to edit the information displayed on the Owner's field.
- x. Access to the **Information Screen**, which displays 9 options (access to the **Information screen** shall be generally provided to only maintainers and system administrators). The maintenance configuration screen shall allow manipulation of:
 - Screen 1
 - i. Initiation of foot protection which guards against a crushing hazard during lowering. This safety system, when enabled, will stop lowering as the column reaches 18 inches above finished floor. At that time, the operator is provided a chance to inspect and ensure that there are no obstructions in the area of the vehicle and lifts. After confirmation that the vehicle and lift area is clear of obstructions, the operator simply needs to retract the mechanical safety locks again and complete the lowering cycle to bring the lift completely to the floor.
 - ii. Ability to disable height difference monitoring to aid in trouble shooting. Once initiated, this control system option allows the maintainer to operate the lifting system outside normal safety limits. This system is only for use by the lift system maintainer during repair procedures. This system option will automatically be disabled and the control system returned to default operating parameters after 10 minutes.
 - iii. Ability to apply a set value to height monitoring system to aid in troubleshooting. Once initiated, this control system option substitutes

a fixed value for the height monitoring device in a particular column. This system is only for use by the lift system maintainer during repair procedures. This system option will automatically be disabled and the control system returned to default operating parameters after 2 minutes.

Screen 2

- i. Ability to select wireless operating channel to minimize interference
- ii. Ability to view total lift system run time to properly plan for lift system maintenance.
- iii. Ability to view individual column motor run time to properly plan for lift system maintenance.

Screen 3 Area to allow for future expansion

Screen 4 (Safety Messages)-area to allow for future expansion

Screen 5 (Maintenance Messages)-area to allow for future expansion

Screen 6 (Back up and Restore)

- I. Ability to restore control system to default settings

Screen 7 (Software Version)

- I. Ability to review system operating information

Screen 8

- I. Ability to establish column type
- II. Ability to establish motor type, VDC or VAC
- III. Ability to establish control system communication protocol
- IV. Ability to enable or disable weight measuring

Screen 9 (Battery Settings)

- i. Ability to establish at what voltage the system will display that the battery system is WEAK
- ii. Ability to establish at what voltage the system will display that the battery system is EMPTY

- c. All control panels shall have automatic synchronization through the full stroke of the hydraulic cylinder with a maximum tolerance of 2 inches (50 mm). Control system will actively control hydraulic correction to maintain level synchronization, unless a column deviates more than 2.4 inches (60 mm) inches from any other column, at which point all motion halts.
 - d. Each column shall be fitted with an individual analog height measuring device. This height measuring device shall ensure that the height of each column in the set remains synchronized at the height initiated by the operator. The height measuring device shall also allow, through single operation, that the operator can raise or lower any column to alternate heights within the tolerances set by the ALI (Automotive Lift Institute) in its manual entitled "*Lifting It Right*".
 - e. The wireless communication system shall utilize mesh-style wireless technology and be properly shielded from external interference in the workshop.
 - f. The mobile column lift battery charger shall operate at the following voltages: 110VAC.
 - g. Control panel shall be rated IP 65.
9. Safety Devices:
- a. An independent and fail-safe mechanical locking system shall be

present on each column. This safety device shall be totally independent from the lifting drive system.

- b. Increments on lifting carriage locking profile shall not be greater than 1.375 inches (35 mm) and the first locking position shall engage after no more than 5.0 inches (120 mm) of lifting.
- c. A locking "pawl and ratchet" system shall be used to ensure proper and automatic locking at any height and at all times. The locking notches shall be integrated into the lifting carriage. The locking pawl shall be mounted to the inside of the column and function as a wedge between the column and the lifting carriage. The locking pawl design shall utilize gravity, with a spring assist, to ensure the locking pawl is always engaged into the locking ladder. The mechanical safety lock shall be automatically engaged at all times when the lift is not operating.

PART 3 EXECUTION

3.1 EXAMINATION

- A. Do not begin installation until substrates have been properly prepared.
- B. If substrate preparation is the responsibility of another installer, notify architect of unsatisfactory preparation before proceeding.

3.2 PREPARATION

- A. Clean surfaces thoroughly prior to installation.
- B. Prepare surfaces using the methods recommended by the manufacturer for achieving the best result for the substrate under the project conditions.

3.3 INSTALLATION

- A. Install in accordance with manufacturer's instructions. Test for proper operation, and re-test if necessary until satisfactory results are obtained.

3.4 PROTECTION

- A. Protect installed products until completion of project.
- B. Touch-up, repair or replace damaged products before substantial completion.

END OF SECTION

stertil **KONN**[®]

MOBILE COLUMN LIFT

ST 1085 - ST 1100

Capacity 18,500 lbs.
or 22,000 lbs.



ebright
SMART CONTROL SYSTEM



STERIL
SUPERIOR SOLUTIONS

Superior Solutions



The Stertil Group provides customized and technically advanced lifting solutions for heavy-duty customers worldwide, as well as the best possible after-sales service from factory trained local partners. These superior solutions are conceived, developed and implemented by a team of specialized professionals with unique experience. Thanks to its quality people, its total in-house production process and its international organization, Stertil-Koni is the world leader in the field of heavy-duty vehicle lifting systems.

Wireless...

Our wireless mobile column lifts with the ebright Smart Control System represent the latest in mobile column lifting technology. Using the innovative ID key, you can connect up to 32 columns in a single lift set. In most cases, the special deep cycle batteries only need to be recharged every two weeks. No time is wasted connecting up cables and the mechanic has maximum access to the vehicle, without any tripping hazards.

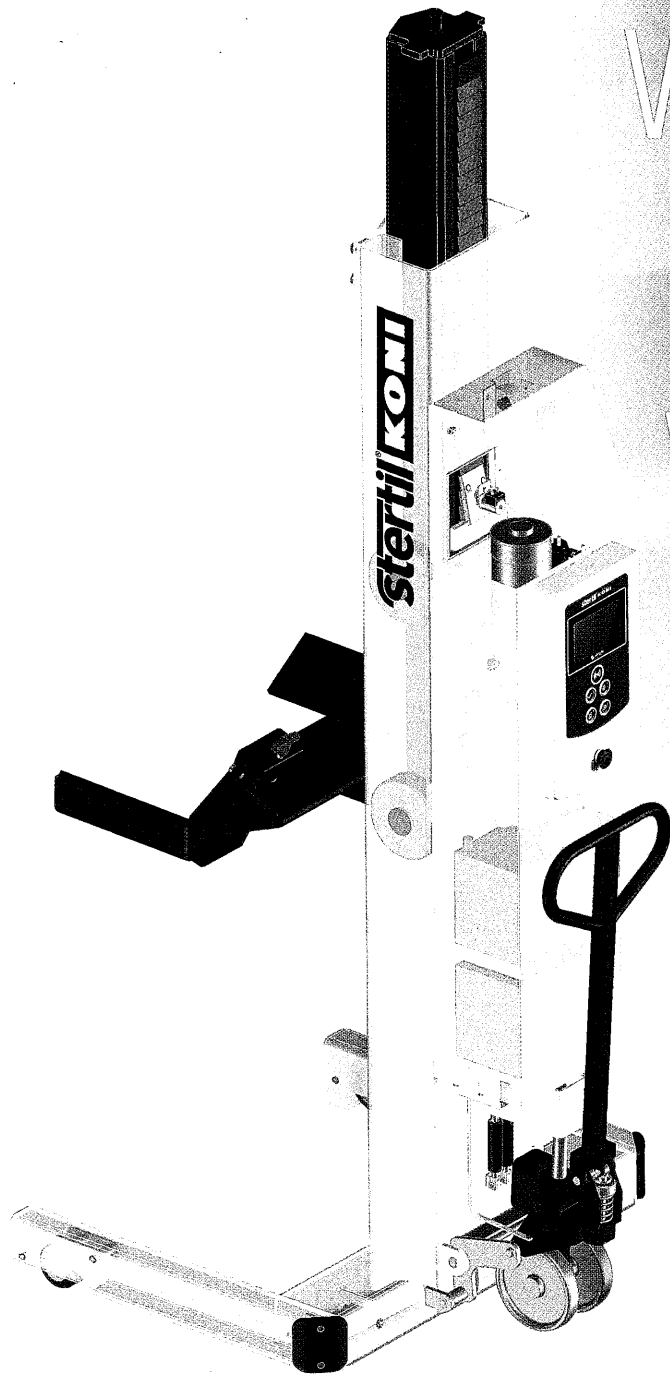

Wireless mobile column lifts with **ebright Smart Control System**

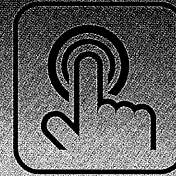

TOUCH SCREEN



WIRELESS



... or cabled, it's up to you

If you predominantly work in a fixed location the cabled mobile column lifts could be the best solution for you. This setup offers the possibility to connect up to 32 columns in a single lift set. All interconnection cables are equipped with heavy-duty plugs at both ends.

Both the wireless and the cabled column lifts are equipped with a control panel on each individual column. Columns can be operated individually, in pairs or simultaneously as a complete set with the touch of a button. Each column can therefore be used at any given location.

Full color touch screen control

The revolutionary **ebright Smart Control System** combines intuitive ease of use with maximum visual information about the lifting process. The main advantages:

- 7" full color touch screen, works even when wearing gloves
- User-configured options, such as choice of language, safety warnings and scheduled maintenance notifications
- All relevant information available at a glance
- Customizable ID-Key to prevent unauthorized operation
- Wireless Mesh network for optimal connectivity

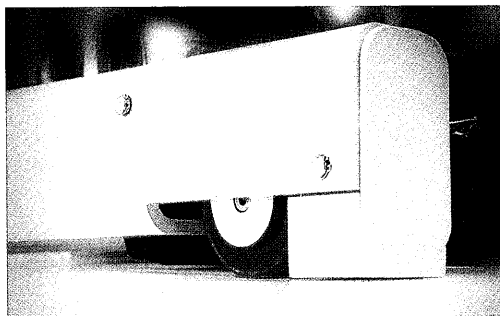
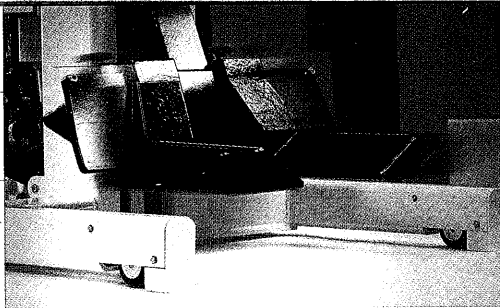

Reliable hydraulic technology

- Extended column life and minimal maintenance thanks to low-friction design
- Stringent testing before leaving the factory
- Manual lowering in case of a power outage
- Maximum protection of the cylinder and seal against damage

Adjustable pick-up forks

ST 1085 mobile column lifts have a fork length of 14", ideal for picking up a variety of vehicles, including vehicles with super single tires in a safe and secure manner. The fork length for the ST 1100 mobile column lift is 12". Both models can handle wheels with rim diameters from R12 to R22.5 with an adjustable fork that is easy to move manually and includes a mechanical lock.

Retractable wheels

Both the wireless and the cabled mobile column lifts are available with retractable wheels. This unique Stertil-Koni design is the best available on the market. This prevents high point loading on the floor and reduces the floor surface pressure by a factor of 10. The system is fast, efficient, very stable and extremely reliable.

Adjustable lowering speed

If you need to lower the vehicle more slowly for precision placement of under carriage components, this is easily done with a single touch.



Power supply

The Stertil-Koni wireless mobile column lifts operate on 24 VDC and are easily recharged by means of a 110 VAC wall receptacle. The Stertil-Koni cabled mobile column lifts operate on three phase at 208/230, 460/480 and 575 VAC, as well as single phase at 220 VAC.

Fast lifting and lowering

The ST 1085 and ST 1100 only take 94 seconds to reach its maximum lifting height of 73". This makes them one of the fastest mobile column lifts in the world.

Well thought out in all aspects



MAX 32 LINKED
COLUMNS



ADJUSTABLE
LOWERING SPEED



OVERLOAD
PROTECTION

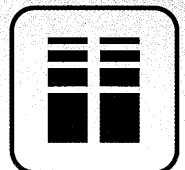

UNIQUE
SYNCHRONIZATION
SYSTEM

Easy to move

Stertil-Koni mobile column lifts are indeed mobile, thanks to the synthetic roller wheels and hydraulic pallet jack mechanism with patented overload protection.

Safe working space

As an extra safety feature, we have also designed ample working space between the column and the vehicle. This ensures that the vehicle will not come into contact with the column in the event of sagging vehicle suspension.

Unique synchronization

The synchronization system is activated at a height difference of just 9/16". This ensures a safe and smooth lifting and lowering cycle, even in cases where the distribution of the vehicle weight is extremely uneven.

Lifetime guarantee

The innovative synthetic runner wheels within the column come with a lifetime parts guarantee.



- High resolution 7" touch screen
- Intuitive controls

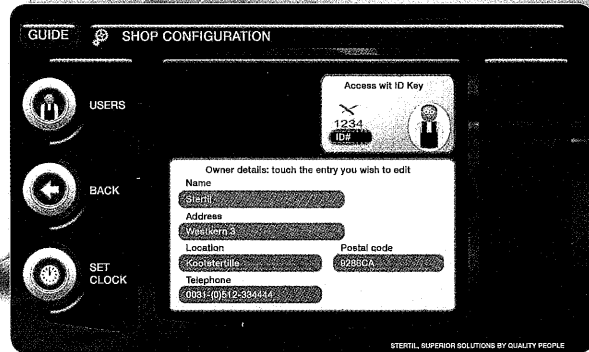
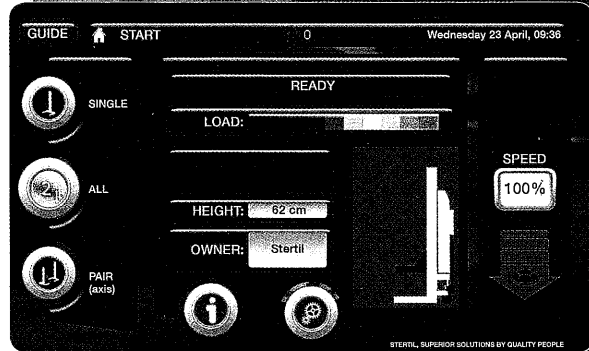

ebright Features

SMART CONTROL SYSTEM

- High resolution 7" touch screen
- Owner/User configurable system with user ID key
 - Individual user settings for setting language and units of measure
 - Protection against unauthorized use, thanks to personalized ID key
- Maintenance notifications
- Visual display of maximum programmable lifting height
- Warning and failure information
- Operation manual available on-screen

- Tracking of specific operations and information codes
- Intuitive controls with actual data about the lift:
 - Indication for Single, All or Pair operation mode
 - Information about how many columns are in the set (up to 32 columns)
 - Actual lifting height displayed
 - Lowering speed can be manually adjusted on the touch screen
 - Battery status information
 - Customizable ID-Key to prevent unauthorized operation
- Wireless Mesh network with continuous active channel search offering optimal connectivity



Everything under control

Overview of ST 1085 – ST 1100 models	ebright wireless ST 1085-FWA ST 1100-FWA	ebright wireless ST 1085-RWA ST 1100-RWA	ebright cabled ST 1085-FSA ST 1100-FSA	ebright cabled ST 1085-RSA ST 1100-RSA
ebright Smart Control System with a control box on each individual mobile column	●	●	●	●
Touch screen with important information about the system e.g. lifting height, operation mode	●	●	●	●
Wireless Mesh network with continuous active channel search offering optimal connectivity	●	●		
These columns utilize a power outlet in the workshop and communicate with each other via interconnecting cables			●	●
Adjustable lowering speed for slow or normal lowering	●	●	●	●
Hydraulic pallet truck mechanism with patented overload protection	●	●	●	●
14"-long adjustable fork, suitable for super single tires	ST 1085	ST 1085	ST 1085	ST 1085
12"-long adjustable fork	ST 1100	ST 1100	ST 1100	ST 1100
Fixed synthetic wheels that reduce the floor surface pressure	●		●	
Retractable synthetic wheels integrated into the base frame, for 10x less floor pressure		●		●

Technical specifications

- Lifting capacity: 18,500 lbs. or 22,000 lbs.
 Lift system: hydraulic lifting system with microprocessor-controlled synchronization
 Lifting height: maximum 73", automatic stop at the highest position
 Lifting time: 94 seconds
 Motor rating: 3 hp / 4 hp per column (Cabled/Wireless)
 Weight: 1,350 lbs per column (Wireless)
 Column lift height: 97"

Highest safety requirements

- ANSI/ALI-ALCTV certified (USA), CSA certified (Canada), CE certified (Europe)
- Independent mechanical locking system engages at 5" above finished floor. Locking pawl engaged by gravity. The locking system is always active, even when the column is turned off
- Locking profile with locking increments of just 1 3/8"
- Synchronization between the mobile lifting columns starts at a height difference of 9/16"
- Automatic overload protection
- Low voltage control panel with emergency stop
- Each column is equipped with hold-to-run push buttons
- Each individual mobile lifting column is tested prior to leaving the factory
- Splash-proof electrical system (IP 65).

Accessories & options

Stertil-Koni offers an extensive package of accessories & options tailored to fit your specific needs.

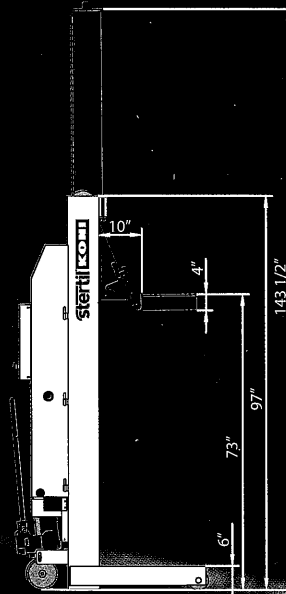

Fixed front wheels

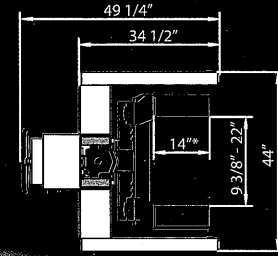

Adjustable forks

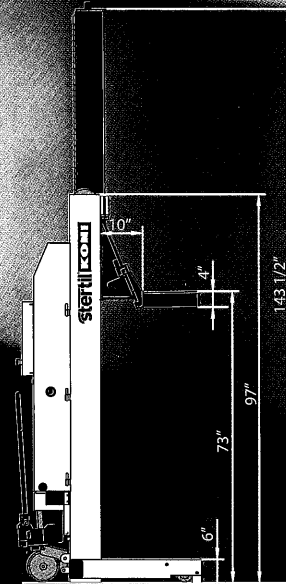

Retractable front wheels

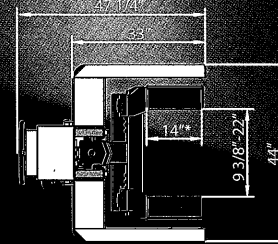

Adjustable forks

For the ST 1100: 12"

More information?

For more information about the ST 1085, ST 1100, or any of Stertil-Koni's other top products, please do not hesitate to contact us. We will be pleased to assist you.



Stertil-Koni U.S.A. Inc.
 200 Log Canoe Circle
 Stevensville, Maryland 21666
 Tel. 410-643-9001
 Toll free 800-336-6637
 Fax 410-643-8901
 www.stertil-koni.com
 lifts@stertil-koni.com

Facebook StertilKoniUSA Instagram @StertilKoniUSA

a member of the Stertil Group

sterti KONI

2019 Comprehensive Shop Equipment

Superior solutions to accompany the world's finest heavy duty vehicle lifts

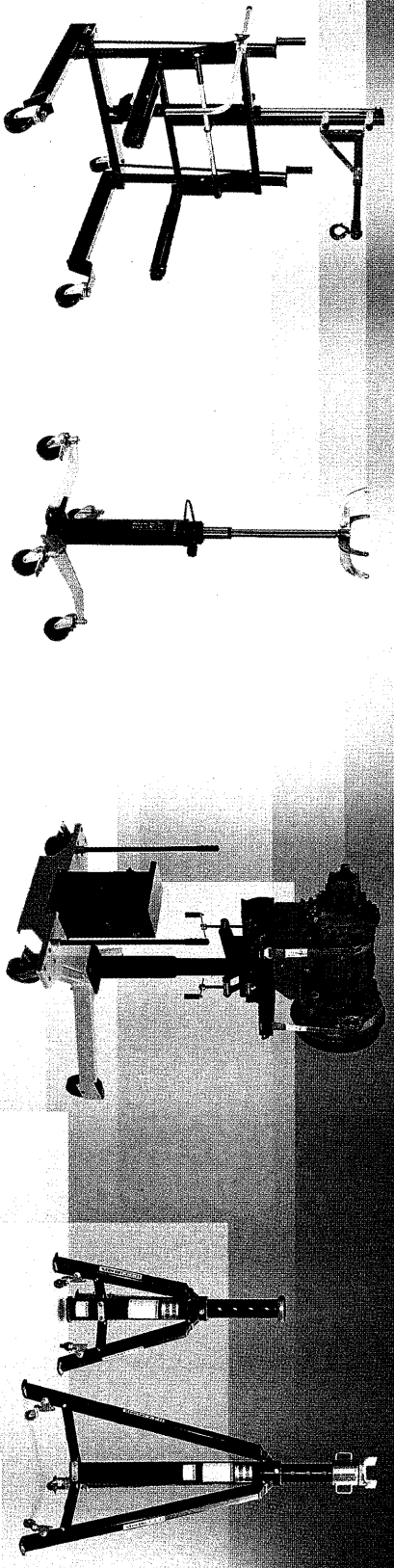

Stertil-KONI

Superior Solutions for Today's Maintenance & Servicing Demands

**Great equipment
to support
great lifts**

Stertil-Koni USA is the leader in the heavy duty vehicle lift industry, recognized for its state-of-the-art bus lifts and truck lifts. Stertil-Koni brings the very best in engineering and technologically advanced lifting solutions to its customers throughout North America, as well as unparalleled after-sales service from its factory-trained local distributors. The Stertil-Koni product range offers everything a shop needs to safely and effectively accomplish a broad range of maintenance and servicing requirements — quickly, efficiently and expertly.

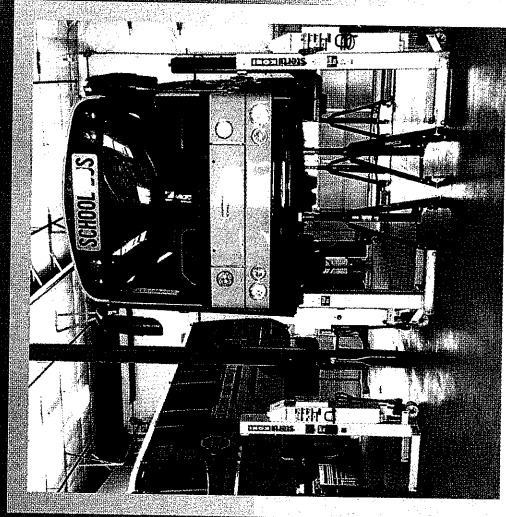
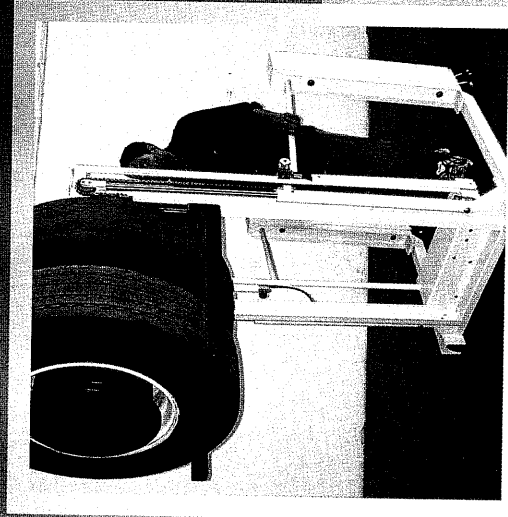
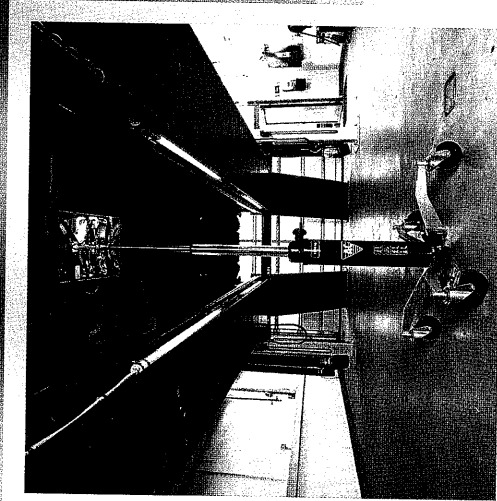

STERLIL-KONI QUALITY



Shop Equipment

Comprehensive Stertil-Koni Heavy Duty Shop Equipment

Stertil-Koni's mission is to maximize the safety and efficiency of your maintenance and service facility. Stertil-Koni offers a comprehensive range of heavy duty shop equipment to meet all your maintenance needs. Our equipment delivers superior design, enhanced ergonomics, safety, durability, and high performance. Explore our exclusive line of shop equipment including Support Stands, Transmission Jacks, Wheel Dollies, Floor Pit Jacks, LED Lighting and more.

Support Stands

Stertil-Koni's Support Stands, indispensable for many of today's leading shops, are engineered to support trucks, buses and other heavy vehicles facilitating a variety of maintenance practices. **All Stertil-Koni Support Stands are statically tested to 200% of the rated load capacity.**

Tilt & Roll

- + Heavy steel framing manufactured to the highest industry standards
- + Ergonomic design promotes health and safety
- + Secure locking pin with steel retaining cable
- + Advanced mobility with built-in wheels
- + Spring-loaded center tube
- + Up to six inches of fine adjustment via an ACME screw (model dependent)

MODEL #	CAPACITY	HEIGHT	HEAD
SKCV 5480-07	14,000 lbs.	54"-80"	1 fixed steel head
SKCP 5278-09	18,000 lbs.	52"-78"	1 fixed steel head
SKMH 3658-12	24,000 lbs.	36"-58"	2 interchangeable heads
SKMH 5480-12	24,000 lbs.	54"-80"	2 interchangeable heads
SKCVP 3658-18	36,000 lbs.	36"-58"	1 fixed wooden head
SKCVP 5480-18	36,000 lbs.	54"-80"	1 fixed wooden head

No Wheels

MODEL #	CAPACITY	HEIGHT	PIN/ADJUST	WEIGHT
SKCP 1220-10	20,000 lbs.	12"-20"	pin stop	27 lbs.
SKCV 1828-10	20,000 lbs.	18"-28"	fine adjust	57 lbs.
SKCP 1830-10	20,000 lbs.	18"-30"	pin stop	39 lbs.
SKCP 2644-10	20,000 lbs.	26"-44"	pin stop	42 lbs.

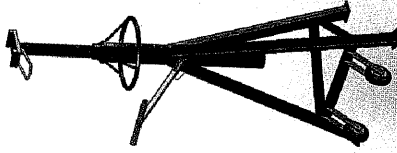

SKCV 5480-07

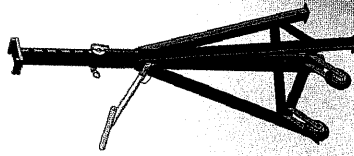

SKCP 5278-09

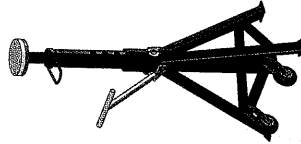

SKMH 3658-12

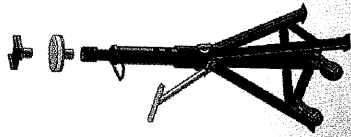

SKMH 5480-12

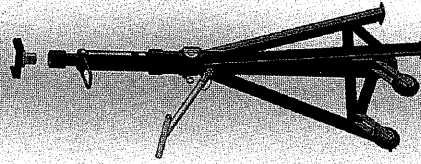

SKMH 5480-12

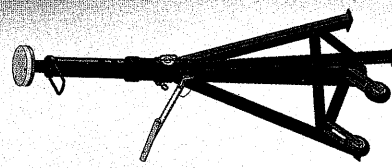

SKCVP 5480-18

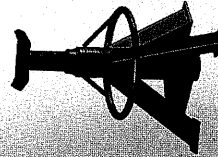

SKCV 1828-10



SKCP 1220-10

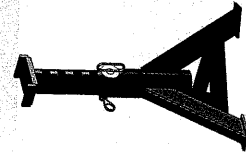

SKCP 1830-10

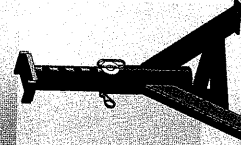

SKCP 2644-10

simple



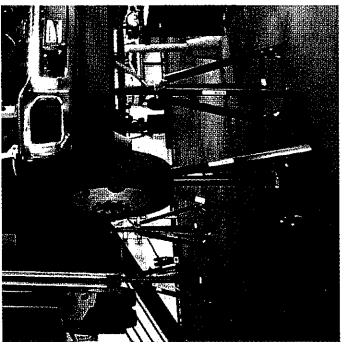

Fixed Model

- + Heavy steel framing manufactured to the highest industry standards
- + Ergonomic design promotes health and safety
- + Secure locking pin with steel retainer
- + 4 pin stops
- + Fixed flat adapter

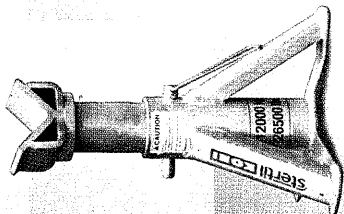

JS-L12

MODEL	PRODUCT #	CAPACITY	HEIGHT	WEIGHT
JS-L12	39225650	26,500 lbs.	14"-21"	40 lbs.

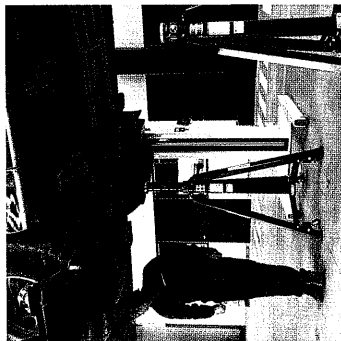

Folding Models

- + Heavy steel framing manufactured to the highest industry standards
- + Ergonomic design promotes health and safety
- + Comes with flat adapter, U-shape adapter and V-shape adapter
- + Fine adjuster
- + Folding with casters
- + Certified by the American Society of Mechanical Engineers (ASME) safety standards for Portable Automotive Service Equipment (PASE)
- + Optional space-saving storage bracket

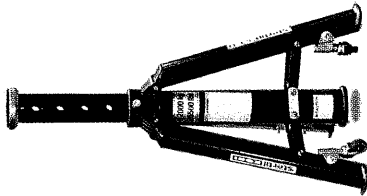

JS-M8 / JS-H8

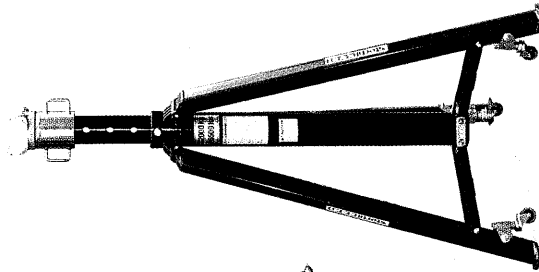

JS-M12 / JS-H12

MODEL	PRODUCT #	CAPACITY	HEIGHT	LOCK POS.
JS-M8	39225645	18,000 lbs.	30"-51"	7
JS-H8	39225625	18,000 lbs.	50"-80"	10
JS-M12	39225635	26,500 lbs.	30"-51"	7
JS-H12	39225615	26,500 lbs.	50"-80"	10

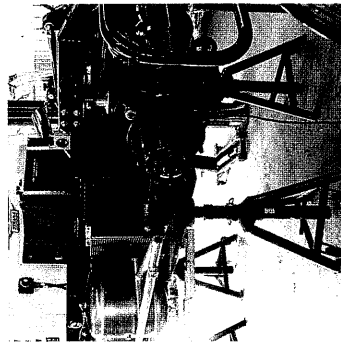

Safe & Essential

World Class Support Stands are available from Steril-Koni. Contact us today at 800.336.6637, lifts@steril-koni.com or find your local Steril-Koni distributor at <https://steril-koni.com/distributors>.

Hydraulic Transmission Jacks

Transmission removals can be daunting. Simplify the task with a durable and reliable Steril-Koni heavy duty Hydraulic Transmission Jack. Our Hydraulic Transmission Jacks are engineered to safely facilitate the removal of transmissions as well as other unwieldy undercarriage components while reducing the physical toll on the shop tech.

Motorized

- + Full hydraulic operation: compressed air or battery powered
- + X-style base frame for additional stability and access to under chassis components
- + Lifting speed of 30" per minute
- + Compressed air model includes regulator, filter, and lubricator
- + Battery model includes smart charger
- + Hand pump to fine-tune positioning
- + Large support table with bidirectional tilt with nylon retaining straps
- + Tilt up to 12 degrees
- + Swiveling locking rear wheels to facilitate narrow radius turns

MODEL #	CAPACITY	POWER	TABLE SIZE	BASE SIZE
SKTJ 401-A	3,500 lbs.	Pneumatic	26"X16"	38"X52"
SKTJ 401-C	3,500 lbs.	Pneumatic	16"X13"	38"X52"
SKTJ 401E-A	3,500 lbs.	12 VDC	26"X16"	38"X52"
SKTJ 402-B	3,500 lbs.	Pneumatic	20"X14"	34"X48"
SKTJ 402E-B	3,500 lbs.	12 VDC	20"X14"	34"X48"

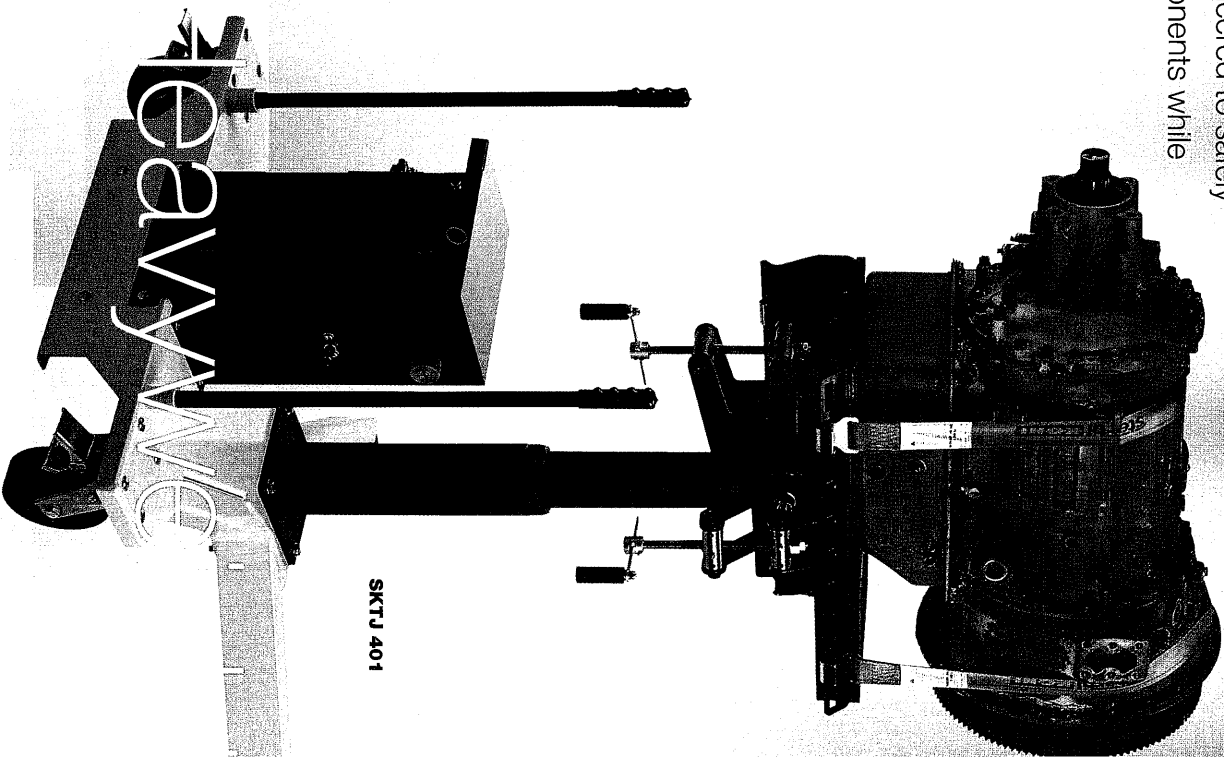

SKTJ 401

Manual Operation

- + Easy to use manual hydraulics, foot activated
- + Galvanized support saddle and base frame
- + Precise adjustment for positioning of transmission
- + Hand-operated dead man's release for optimum safety when lowering
- + Built-in overload valve
- + Sturdy swivel castors for stability and maneuverability

MODEL	PRODUCT#	CAPACITY	HEIGHT	CRADLE SIZE	WEIGHT
TJ10	39640200	2,200 lbs.	46"-78"	22"X22"	88 lbs.
TJT12	39640250	2,640 lbs.	35"-75"	28"X28"	154 lbs.



SKTJ 402

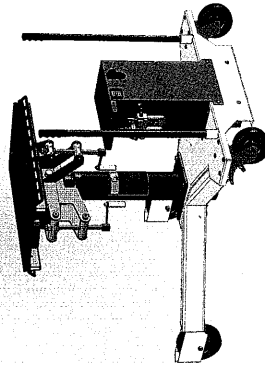

SKTJ 402

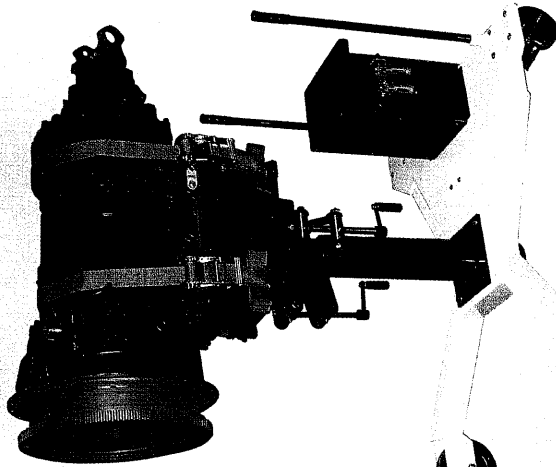

SKTJ 402

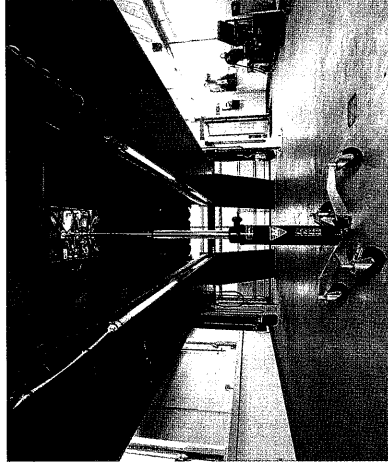

TJ-10



TJ-12

Made in

World Class Hydraulic Transmission Jacks are available from Steril-Koni.
 Contact us today at 800.336.6637, lifts@steril-koni.com or find your local
 Steril-Koni distributor at <https://steril-koni.com/distributors>.

Manual Transmission Jack Options

Heavy Duty Adjustable Saddle

Product #39630140

- + Capacity 2,200 lbs.
- + 10° tilt in all directions for accurate dismounting and re-mounting of transmissions
- + Low minimum height for wide range of applications
- + Table dimensions 20"X15"
- + Includes 2 straps and 4 magnetic rubber support blocks
- + Weight 55 lbs.



39630140

Saddle

Product #9059500

- + Round steel contact adapter
- + For mounting springs, fuel tanks, etc.

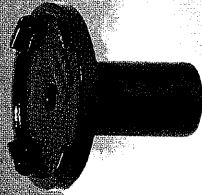

9059500

Rubber Lifting Cushion

Product #3601400

- + Used with saddle #9059500
- + Protects vehicle body

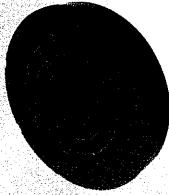

3601400

* Options not available on all models.

stertil[®]KONI

Number One in Heavy Duty Vehicle Lifts

*Keep your fleet
mobile with
Stertil-Koni*

EARTHLIFT

Mobile Column Lift

DIAMONDLIFT

In-Ground Piston Lift

ECOLIFT

In-Ground Scissor Lift

SKYLIFT

Platform Lift

MULTI-POST

2 and 4-Post Lifts

STERLIL-KONI LIFTS

www.Stertil-Koni.com



Wheel Dollies

Wheel and tire maintenance ranks among the most back-breaking tasks in maintenance shops across North America. Add ergonomic convenience to your facility with the Steril-Koni Wheel Dolly and the picture gets brighter. This fully hydraulic versatile shop tool offers support for virtually all heavy vehicle wheel assemblies, from vans, buses, and trucks to agricultural, military, and industrial machinery. Additionally, it offers support for brake drums, fuel tanks, and other ungainly overhead maintenance.

Motorized

- + Fully hydraulic operation: powered by compressed air or 12 VDC battery
- + Easily handles single and dual wheel applications
- + Lifting forks incorporate rollers to allow rotation of wheel assembly to align wheel studs
- + Lifting forks tilt through activation of hand pump for precision bearing alignment
- + Tilt is 10 degrees above and 4 degrees below horizontal
- + Nylon retaining strap secures load
- + Protective steel cover to prevent foot injuries and increase stability
- + Wheel diameter is 36" to 48"

MODEL #	CAPACITY	POWER	LIFTING HEIGHT	SPEED/MIN.
SKWD 501*	850 lbs.	Pneumatic	52"	78"
SKWD 500	1,000 lbs.	Pneumatic	52"	78"
SKWD 500E	1,000 lbs.	12 VDC	52"	78"
SKWD 500D74	1,000 lbs.	Pneumatic	74"	78"
SKWD 500E74	1,000 lbs.	12 VDC	74"	78"

*Counterbalance design for Platform Lifts

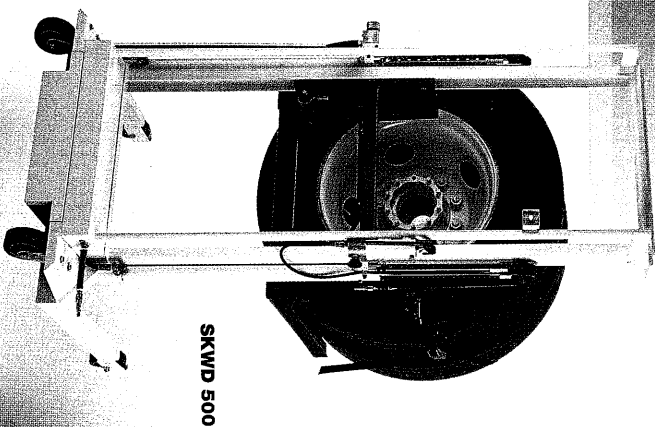

SKWD 500

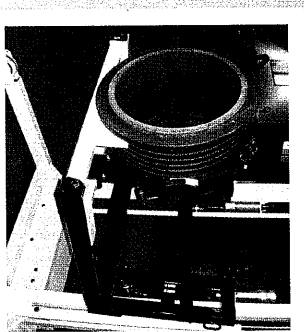

SKWD 500

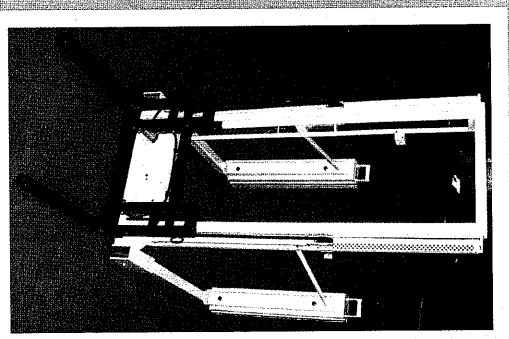

SKWD 501

EVERETT SHOP

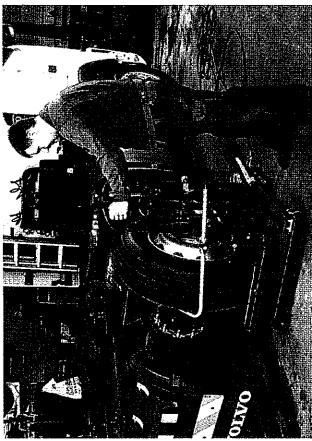

Manual Operation

- + Specially designed adjustable side lifting arms accommodate agricultural and industrial wheels with larger diameters and widths — even deep tread tractor tires
- + Lifting arms incorporate rollers to allow rotation of wheel assembly for proper alignment
- + Robust and easy to use wheel retaining bracket for added safety
- + Simple manual operation by foot

WDA 500

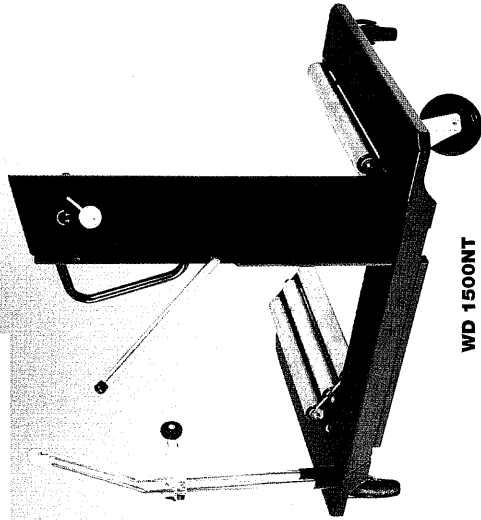

WD 1500NT

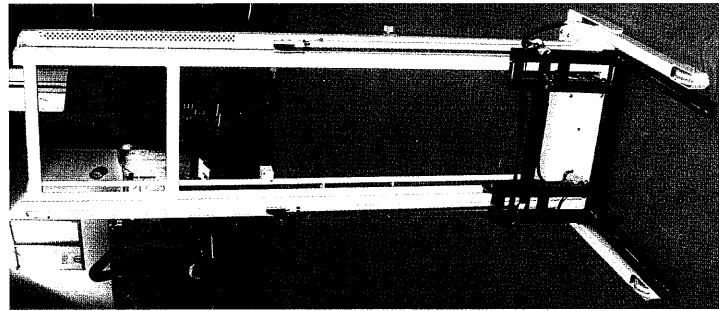

SKWD 500D74

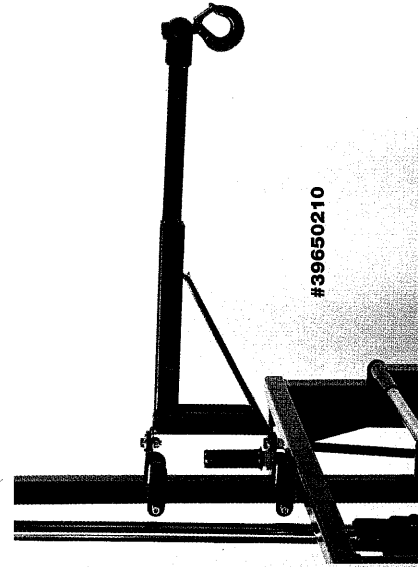

#39650210

MODEL	PRODUCT#	CAPACITY	LIFTING POWER	WHEEL HEIGHT	DIAMETER
WDA 500	39650100	1,100 lbs.	Manual	28"	10"-51"
WD 1500NT*	39650200	3,300 lbs.	Manual	54"	39"-94"
WD 1500N*	39650150	3,300 lbs.	Manual	54"	39"-94"

* Agriculture use

Manual Wheel Dolly Option

Crane Arm

Product #39650210

- + For model WDA500
- + Capacity 550 lbs.
- + Mounted telescopic crane arm transforms the WD into a universal lifting tool
- + Offers efficiency and good ergonomics when lifting disc brakes, brake drums, calipers, etc.
- + Swivels aside for quick reversion to wheel removal operation
- + Fitted with 360° pivoting hook

Safety

World Class Wheel Dollies are available from Stertil-Koni.
 Contact us today at 800.336.6637, lifts@stertil-koni.com or find your local Stertil-Koni distributor at <https://stertil-koni.com/distributors>.

Floor Pit Jacks

Stertil-Koni has taken a traditional standard air hydraulic pit jack and made it better.

The Floor Pit Jack is an air hydraulic jack with telescopic ram, fitted with leaf spring support bearings for smooth gliding along the pit floor. This Floor Pit Jack is designed to operate on pit floor surfaces safely, thereby not depending on pit edges that are often not reinforced or sufficiently strong.

Floor Running

- + Rapid, precise air/hydraulic unit with high speed ram travel up and down
- + Built-in manual foot pump for easy and precise adjustment
- + Flexible pit jack for use both in pits and under vehicles
- + Ideal for R & R of transmissions due to telescopic ram
- + Traversing ram ensures a wide reach under the vehicle and enables the mechanic to move freely back and forth in the pit (Model FPJ150U)
- + Spring loaded wheel support prevents unintended movements when lifting more than 1,760 lbs.
- + Dead man's release and safety overload valve for optimum safety

MODEL	PRODUCT#	CAPACITY	RAM	HEIGHT**	BASE
FPJ 150 F	39660100	33,000 lbs.	single	87"	33"X39"
FPJ 150 U*	39660200	33,000 lbs.	single	87"	33"X42"

* Telescopic and sideways movable cylinder

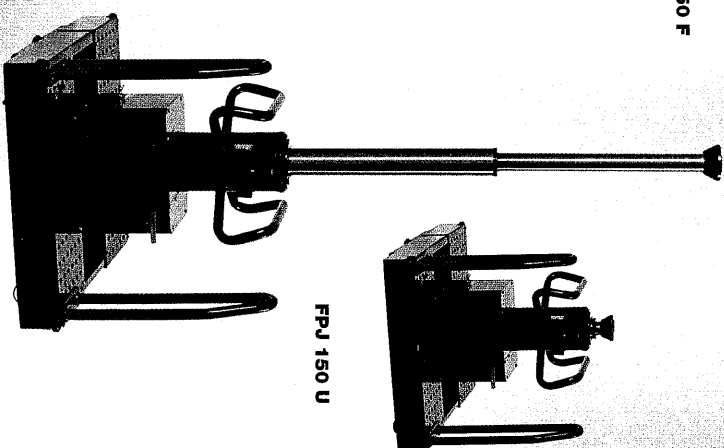
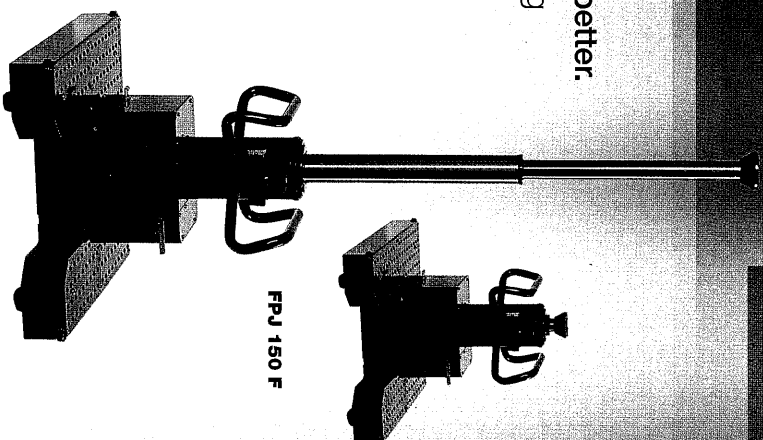

World Class Floor Pit Jacks are available from Stertil-Koni
Contact us today at 800.336.6637, lifts@stertil-koni.com or find your
local Stertil-Koni distributor at <https://stertil-koni.com/distributors>.

Floor Jack Options

Adjustable Crossbeams

MODEL	PRODUCT#	CAPACITY	HEIGHT	ADJUST RANGE	PISTONS
T6-1	39630135	28,600 lbs.	3"	28"-48"	single
T6-2	39615135	28,600 lbs.	3"	28"-48"	tandem
T4-1	39630125	33,000 lbs.	4"	7"-29"	single
T4-2	39615130	33,000 lbs.	5"	7"-29"	tandem

Transmission Tables

Product #39660210 and AS3, Product #3966140

- + Capacity 1,100 lbs.
- + Table dimensions 20" x 15"
- + For single piston models

ABT Variable Support Bridge

Product #39630121

- + Capacity 33,000 lbs.
- + For safe and stable support of the vehicle
- + Open frame offers optimum traversing cylinder mobility
- + With leaf spring wheels for easy transport along the pit
- + Usable with various adapters
- + For use with FPJ jacks

AB Support Bridge

Product #39630120

- + Capacity 44,000 lbs.
- + For safe and stable support of the vehicle
- + With leaf spring wheels for easy transport along the pit
- + Usable with various adapters

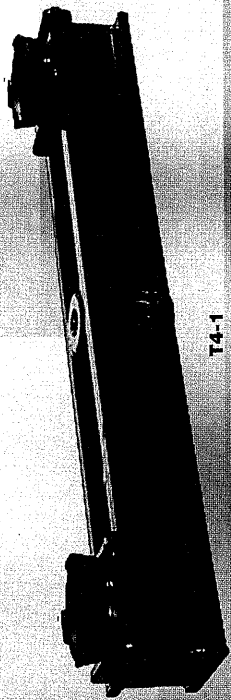

T4-1



T6-1

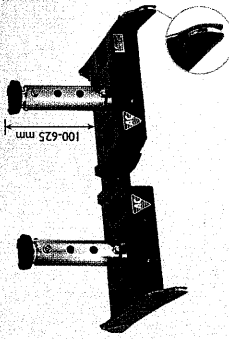

39630121

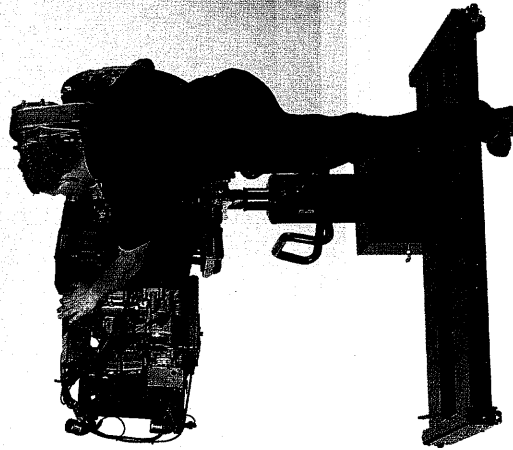

Light Up Your Workspace

LED Magnetic Flood Light

Providing portable, area-specific under-vehicle lighting is vital to ensuring shop safety and efficiency. Whether techs are doing routine maintenance, removing components or installing new parts, lights brighten the environment and help reduce overall repair time. The Stertil-Koni LED Magnetic Flood Light is a portable, magnetic, high-intensity 10-watt LED light engineered to easily affix to a broad range of metal surfaces commonly found in vehicle maintenance shops.

LED Magnetic Flood Light Set

Product #69700141

- + Includes: lamp, battery, charging unit and tripod
- + Provides up to 800 lumens of directed light
- + Powered by rechargeable lithium-ion battery
- + Die-cast aluminum housing
- + IP65 dust and water resistant
- + Strong magnetic base
- + 110 VAC charging cord — Product #69700146

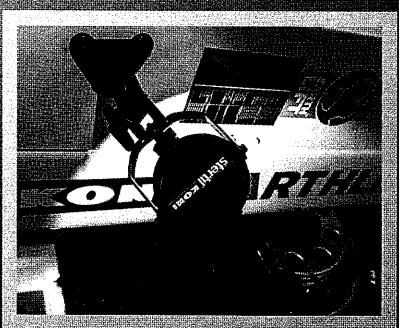
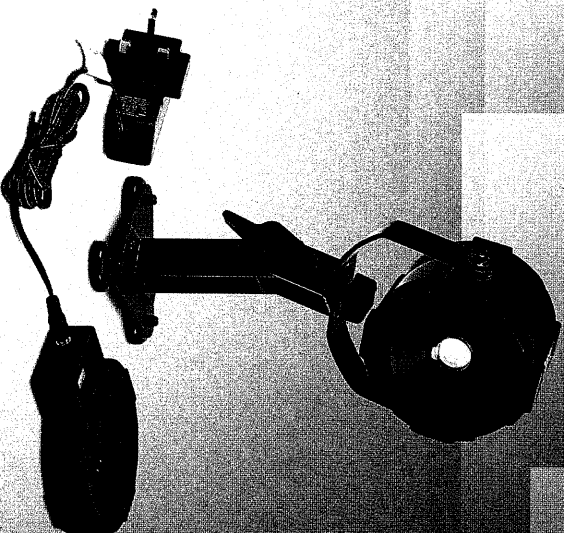

World Class LED Magnetic Flood Lights are available from Stertil-Koni. Contact us today at 800.336.6637, lifts@stertil-koni.com or find your local Stertil-Koni distributor at <https://stertil-koni.com/distributors>.

sterdil® KONI

Trustworthy

"Service and support from Stertil-Koni is something our maintenance staff gets directly involved in. Stertil-Koni's support has been outstanding, which is why we buy their products. It has been a long lasting successful partnership.

Would I buy another Stertil-Koni product? Would I recommend Stertil-Koni? Yes, I would."

— **Bob Graden**
Plant Manager
Vac-Con
Green Cove Springs, Florida

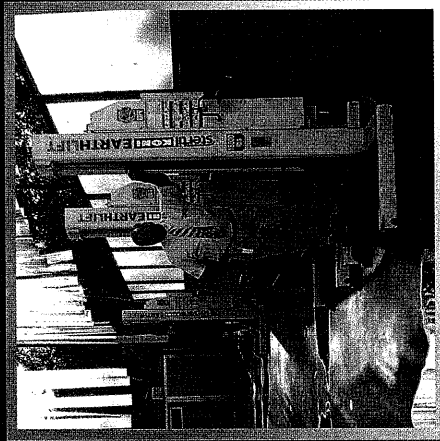

"D'Annunzio & Sons always bases its choices on quality — with the final, customer project in mind. We have quality people, equipment, and vehicle lifts — all of which positively impact job performance and completion time."

— **John Cafro**
Equipment Manager
D'Annunzio & Sons, New Jersey

Pictured to left is Matthew Morgan, Principle at Stertil-Koni Distributor, Hoffman Services Inc.

